

Instruction manual

Vortex Flow Meter

TYPE : VFM 8300 Series



ientek Co., Ltd.

Factor 2 (P)153-803

Daeryung Technotown 5th #407 493, Gasan-dong Gumcheon-Gu, Seoul, Korea

TEL : +82-2-2107-7999 FAX : +82-2-2107-7990

Head Office & Factory 1 (P) 425-791

4th Engineering B/D ansan Technopark #401, 1271, Sa 1-dong, ansan, Kyonggi-do, Korea

TEL: +82-31-416-2228 FAX : +82-31-416-2338

[http:// www.flowmeter.co.kr](http://www.flowmeter.co.kr) , E-mail : master@flowcountry.com

CONTENTS

Chapter 1. Application and feature	3
VFM 8300 Series Vortex Flow Meter	3
Note and safety Information	4
Receipt of system components	4
Technical Assistance	4
Vortex flow meter Introduction	5
Vortex flow meter operating Principle	5
Ambient condition and technology specification	7
Chapter 2. Basic composition and detailed parts	9
Basic composition of flow meter	9
Flow meter Size(Wafer)	9
Detailed composition parts	10
Flow meter Size (Insert)	11
Chapter 3. Installation and electric wiring	12
Fittings	12
Installation	12
Installation select of site	12
Piping installation and requirement	12
Vortex installation of flow meter	13
Basic piping drawing	14
Wire connection	15
Chapter 4. Installation test and adjustment	17
Static operating of sensor Amp point table 6 reference	17
Meter constant of flow sensor	17
Sensitivity adjusting	18
Chapter 5. Re-assemble	20
Sensor Amp re-assemble	20
Sensor inspection separation	20
Chapter 6. Troubleshooting and Repair	21
Supplement (Integrated flow rate meter-XSJ/XSJB)	22

Warnings and Cautions

- Warning!** All wiring procedures must be performed with the power Off.
- Warning!** To avoid potential electric shock, follow National Electric Code safety practices or your local code when wiring this unit to a power source and to peripheral devices.
Failure to do so could result in injury or death.
All AC power connections must be in accordance with published CE and KS directives.
- Warning!** Remove the pressure on the line before repairing the flow meter.
- Warning!** Turn power off before disassembling any component of the flow meter.
- Caution!** Printed circuit boards are sensitive to electrostatic discharge. To avoid damaging the board, follow these precautions to minimize the risk of damage :
- before handling the assembly, discharge your body by touching a grounded, metal object
 - Keep any electronic board not related to the flow meter away from the flow meter.
 - when possible, use grounded electrostatic discharge wrist straps when handling sensitive components

Chapter 1. Application and feature

VFM 8300 Series Vortex Flow Meter

VFM 8300 Series vortex flow sensor is a new stress inspection-type vortex flow sensor made of piezo crystal measuring parts.

This flow meter boasts a wide flowrate range(turn-down Ratio), high level of accuracy, low level of press drop, high level of circulation and a pulse signal output proportionate to flowrate.

It can also be connected to a computer.

The sensor used in this flow meter can be installed separately from the vortex generator, and the high-temperature piezo crystal inside does not contact directly with the measuring device.

This flow meter has a simple structure and high level of stability.

Vortex flow sensor is used to inspect and calculate a variety of gas, liquid and steam.

VFM vortex flow sensor can be used with XSJ, XSJB and XSJDL integrated flow rate sensor.

It can also be used with a computer or temperature, pressure and density sensors to form a high-accuracy mass flowrate, a heat flowrate or an inspection system.

Note and Safety Information

We use alarm signs to arouse attention on important information.

Warning!

This reference represent very important information for prevention to damage of item and human life.

Caution!

This reference represent very important information for protection of performance and item.

Reference!

This reference represent for inform to important detail data.

Receipt of System Components

When receiving a ientek Vortex flow meter, carefully check the outside packing carton for damage incurred in shipment.

If the carton is damaged, notify the local carrier and submit a report to the factory or distributor.

Remove the packing slip and check that all ordered components are present. Make sure any spare parts or accessories are not discarded with the packing material.

Consult ientek before returning the product.

Technical Assistance

If any problem arises with the flow meter, check each step of installation and operation and confirm that you set and adjusted the flow meter according to the guideline of the manufacturer.

For detail information and actions, refer to Chapter 6. Fault Diagnosis of the instruction manual.

If the problem persists in spite of the fault diagnosis procedure in Chapter 6, consult ientek by fax or email (see our website) or call +82-02-2107-7997 from 9AM till 6PM.

When contacting Technical Support, make sure to include this information :

- The flow range, serial number and ientek order number (All marked on the meter nameplate)
- The problem you are encountering and any corrective action taken
- Application information (Fluid, Pressure, Temperature and piping configuration)

Vortex flow meter Introduction

Vortex flow meter used for industrial purposes employs KARMAN's vortex principle.

The KARMAN vortex principle is clearly illustrated by such natural phenomena as tremor at the end of grass generated by streams of water, sound of cable created by wind and a flag waving in the wind. When a columnar object is placed in the flow path of a fluid, regular channels of vortices, called Karman vortex channels, are generated at the back of the object.

Karman proved these regular and stable conditions of the vortex channels in equation.

Research on Karman swirling vortex channels began with perspectives on damaged done to pipelines of heat exchange systems and tremor of structures (i.e. bridges) placed in the flow path of a fluid.

Vortex flow meter operating principle

There are two types of vortex flow meters – one detects velocity by measuring the frequency of vortices, and the other detects pressure by measuring the frequency of force imposed on vortex generators (shedders and bluff body).

Vortices are formed as the fluid flows around the shedder body which are alternately shed from its sides. The flow causes these vortices to be released forming a vortex street (Karman Vortex Street), see Figure 1-1.

The frequency f of the vortex shedding is proportional to the flow velocity v and inversely proportional to the width of the shedder body d :

$$f = Sr \cdot \frac{V}{d} \quad \text{---- (1)}$$

Sr , the Strouhal Number, a dimensionless number, defines the quality of the vortex flowrate measure.

By appropriate design of the shedder body, Sr is constant over a wide Reynolds Number

Re range (Figure 1-2).

f – column side vortex separation frequency (Hz)

V – column side flow velocity (m/s)

d – Meter tube diameter (m)

Sr – STROUHAL number. Characteristics of fluid relevant to cross section area of the column, constant regardless of size of flow velocity,

$Sr : 0.17 \sim 0.18$

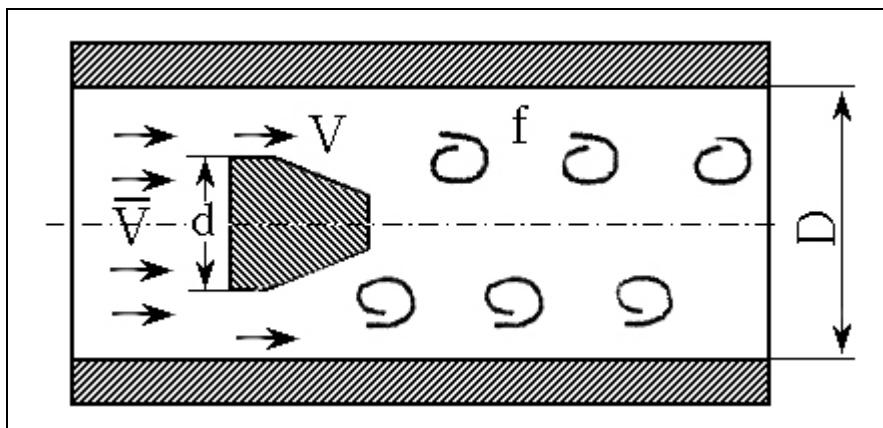

Figure 1-1. Circle pipe inside Vortex

Dimensional analysis shows that the Strouhal number of the vortex pattern governs the frequency of vortex shedding f, v

where D_c is the diameter of the cylinder or width of the barrier and V is the flow velocity

$$Re = \frac{v \cdot d}{\nu} \quad \text{---- (2)}$$

The relationship with the formula (1) is also established in stream of flow in the diameter of the pipeline D , so where flow rate is Q and flow velocity of vortex generator (v) equals Q

$$\text{Flow velocity}(v) = \frac{Q}{\pi/4 D^2 d.D}$$

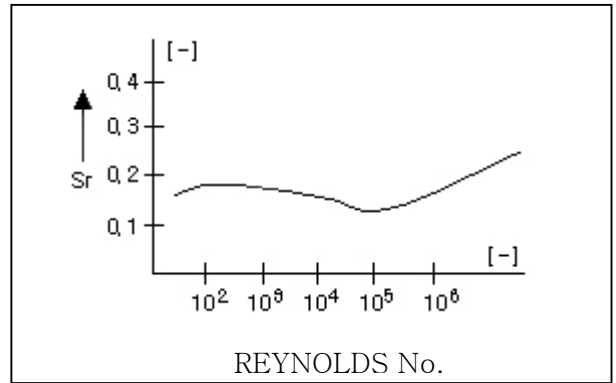

Figure 1-2. REYNOLDS Number.

$$\text{Vortex generation frequency}(f) f = \frac{Sr}{d[\frac{\pi}{4}] D^2 - d.D} \cdot Q = K \cdot Q \quad \text{---- (3)}$$

With K value, $d.D$ is a precondition of production, and the number of Strouhal (Sr) is determined by the shape of a vortex generator. Therefore, the frequency is a function of flow rate.

By detecting the frequency of generation, you can get the flow rate (Q).

Meter coefficient K -Factor is Liter/Pulse.

There is a fixed rate between the width of column d and the diameter of the pipeline D in design of VFM series vortex flow transmitter. There is also a fixed rate between the average flow velocity \bar{V} and velocity next to the column V .

$$\bar{V}/V = 1 - 1.25d/D$$

With :

$$f = Sr \frac{V}{d} = Sr \frac{\bar{V}}{(1 - 1.25d/D)d}$$

$$\bar{V} = \frac{1}{Sr} \times f (1 - 1.25d/D)d$$

D and d is the size of every structure, and Sr is a constant. When vortex separation frequency f is measures, you can know the average flow velocity in the pipeline and detect flow rate Q .

$$Q = 3600F \cdot \bar{V} \quad (\text{m}^3/\text{h})$$

Formula : F – Transmitter Circulation area of main body (m^2)

\bar{V} – Transmitter average flow velocity of main body (m/s)

Pulse pressure is generated in tail fluid on the both sides and on the back side of the column, and the pulse pressures on the detected part of the inside or the backside of the column is working. The piezo crystal parts installed inside the detected area is under stress, then changes electric charge signals.

The detection amplifier changes replaced and altered electric charge signals, and process the amp, filt and signal shaping. Electric currents (or voltage) pulse signals where the output frequency and the frequency of vortex separation are the same.

The medium pulse output from the sensor refers to un-measurement fluid with certain volumes. The total number of output pulses within certain time refers to the total volumes of liquid streaming by the sensor.

Ambient condition and technology specification

Ambient Condition

Ambient Temperature : -40℃ ~ 55℃

Relative Humidity : 5% ~ 90% RH

Atmospheric Pressure : 86~106KPa

Unmeasured fluid : single-component fluid or fluid considered single-component fluid

Technology specification

Pipe size(DN) : 25~900mm

Measurement Medium : Liquid, Gas, Steam

Medium Temperature : -40℃ ~ 350℃

Linearity : $\leq \pm 1.0\%$

Connection Method : Flange, wafer type, Insert type($\geq 250\text{mm}$)

Power supply : 24V DC

Output Signal : Current pulse, low level $4 \pm 0.5\text{mA}$, high level $20 \pm 1\text{mA}$

Standard Pressure : 2.5MPa, 4.0MPa, 6.9MPa (Special Custom-built)

Accuracy : 1.0%, 0.5% (Custom-built), insert : 2.5%

Repeatability : $\leq 0.5\%$

Wetted Materials : ICr18Ni9Ti

Load Capacity : $\leq 350\Omega$

Enclosure : IP65

Explosion Class : ia II CT1~6(nature safety) Safety barrier power distribution unit

D II BT4(internal pressure) Power supply Power

Relation Equipment : XSJ, XSJB, XSJDL (Flow computer)

Table 1. Flow rate range

Sensor Model	DN mm	Flow rate range (m ³ /h)			Sensor Model	DN mm	Flow rate range (m ³ /h)		
		Liquid	Gas	Steam			Liquid	Gas	Steam
VFM	25	1~10	10~97	9~80	VFM	250	80~1100	1000~10000	850~8500
VFM	40	2~30	24~230	20~190	VFM	300	100~1600	1500~15000	1200~12000
VFM	50	3~40	40~370	30~300	VFM	350	140~2000	2000~20000	1620~16200
VFM	65	5~70	63~630	50~500	VFM	400	180~2700	2700~27000	2100~21000
VFM	80	7~100	97~970	80~800	VFM	500	280~4000	4230~42300	3300~33000
VFM	100	10~160	152~1520	125~1250	VFM	600	400~6000	6100~61000	4780~47800
VFM	125	20~260	240~2430	200~2000	VFM	700	550~8300	8300~83000	6500~65000
VFM	150	25~370	350~3500	280~2800	VFM	800	720~10800	10850~108500	8500~85000
VFM	200	50~720	660~6600	540~5400	VFM	900	710~13700	13740~137400	10700~107000

(Preceding descriptions flowrate value is related in temperature, pressure, density etc. with volume flowrate.)

Note.1) : The range of flow rate in the table 1 has been corrected in the following standard conditions.

Gas temperature 0°C, 1 atmospheric pressure air. ($\rho_0=1.293\text{kg} / \text{m}^3$)

Liquid 4°C water ($\rho_0=1000\text{kg} / \text{m}^3$)

Vapor is dry saturation steam in absolute pressure of 0.4MPa. ($\rho_0=2.1628\text{kg} / \text{m}^3$)

Fluid conditions are as above. When measuring other fluids, the range of flow rate of the transmitter is affected by density and viscosity.

Then, the range of flow rate can be calculated with the following method.

(1) Based on the low limit Q_{\min} shown in the table 1, basis fluid density ρ_0 (Gas $\rho_0=1.293\text{kg}/\text{m}^3$; Liquid $\rho_0=1000\text{kg}/\text{m}^3$; Steam $\rho_0=2.1628\text{kg}/\text{m}^3$) and used fluid density ρ and low-limit flow rate Q_{\min} of density of other fluid used:

$$Q_{\min} = Q_{\min} \sqrt{\rho_0 / \rho} \text{ (m}^3/\text{h)}$$

(2) By the movement viscosity of fluid ν , the low-limit flow rate viscosity output $Q_{\min \nu}$

$$Q_{\min \nu} = 6 \nu D \times 10^4 \text{ (m}^3/\text{h)}$$

D – Pipe inside (mm)

ν – Movement viscosity (m^2/s)

Compare $Q_{\min \rho}$ and $Q_{\min \nu}$, and select the larger value to set the value as the low limit flow rate of fluids when measuring fluid of this flow meter.

High limit flow rate of various fluid table 1 reference.

In general, the high-limit flow velocity of liquid is 6m/s, and the high-limit flow velocity of gas or steam is 45m/s.

Note.2) : Resistance Factor C_d of the flow rate sensor is 2.2, and the resistance drop of the sensor is calculated with the following formula when flow rate is different.

$$\Delta P = C_d \frac{\rho}{2 \bar{V}^2}$$

ΔP – Resistance drop (Pa)

ρ – Fluid density (kg/m^3)

\bar{V} – Inside pipe average flow velocity. (m/s)

Note.3) : When used fluid is liquid, the fluid pressure around the sensor P must satisfy the following formula so as to prevent erosion of vaporization gas.

$$P > 2.6 \Delta P + 1.25 P_s$$

ΔP – Press loss Calculation value

P_s – Pressure (Kpa) of liquid saturation steam applied to working temperature

P – Fluid pressure (Kpa)

Chapter 2. Basic Composition and Detailed Parts

Basic composition of flow meter

VFM 8300 Series sensor includes the main body (14), a tripod (15), a detector (19), a connection support probe (10) and an inspection amp case (5), an electronic circuit board (6) and other supplied accessories.

Unmeasured fluid detects vertex separation signals at the detector when passing by the main body, and the inspection amp changes the signals to send frequency signals to the integrated flow rate meter. Connection probe is connection action shield and heat emission actions.

Flow meter Size(Wafer)

The composition and size of different calibration and structure of sensors are shown in the figure 2-1 and the table 2.

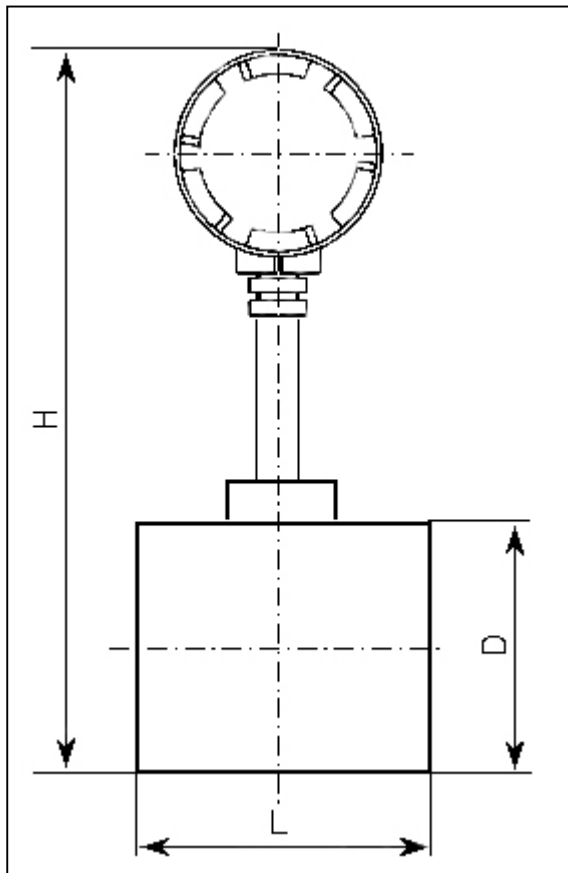

Table 2. VFM 8100 Series Wafer Type Size(mm)

DN	Inner dia.	Wafer Type Body		
		L	Outer D	H
25	25	80	76	344
40	39	80	76	335
50	49	80	86	346
65	64	80	102	362
80	79	80	112	374
100	99	80	132	395
125	125	80	175	433
150	149	80	202	458
200	207	100	258	515
250	259	120	311	568
300	309	140	362	618

※ Note) :

- (1) When measured fluid is steam, the device must increase by H 60mm. A heat generator exists.
- (2) Flange type body can be manufactured when required by the user.

Figure 2-1. Wafer Type Size

Detailed composition parts

Sensor Amp. Electric charge transmitter, voltage amp, main body, Vortex generator.

The meter consists of 6 areas including power circuits and voltage/current pulse switching circuits.

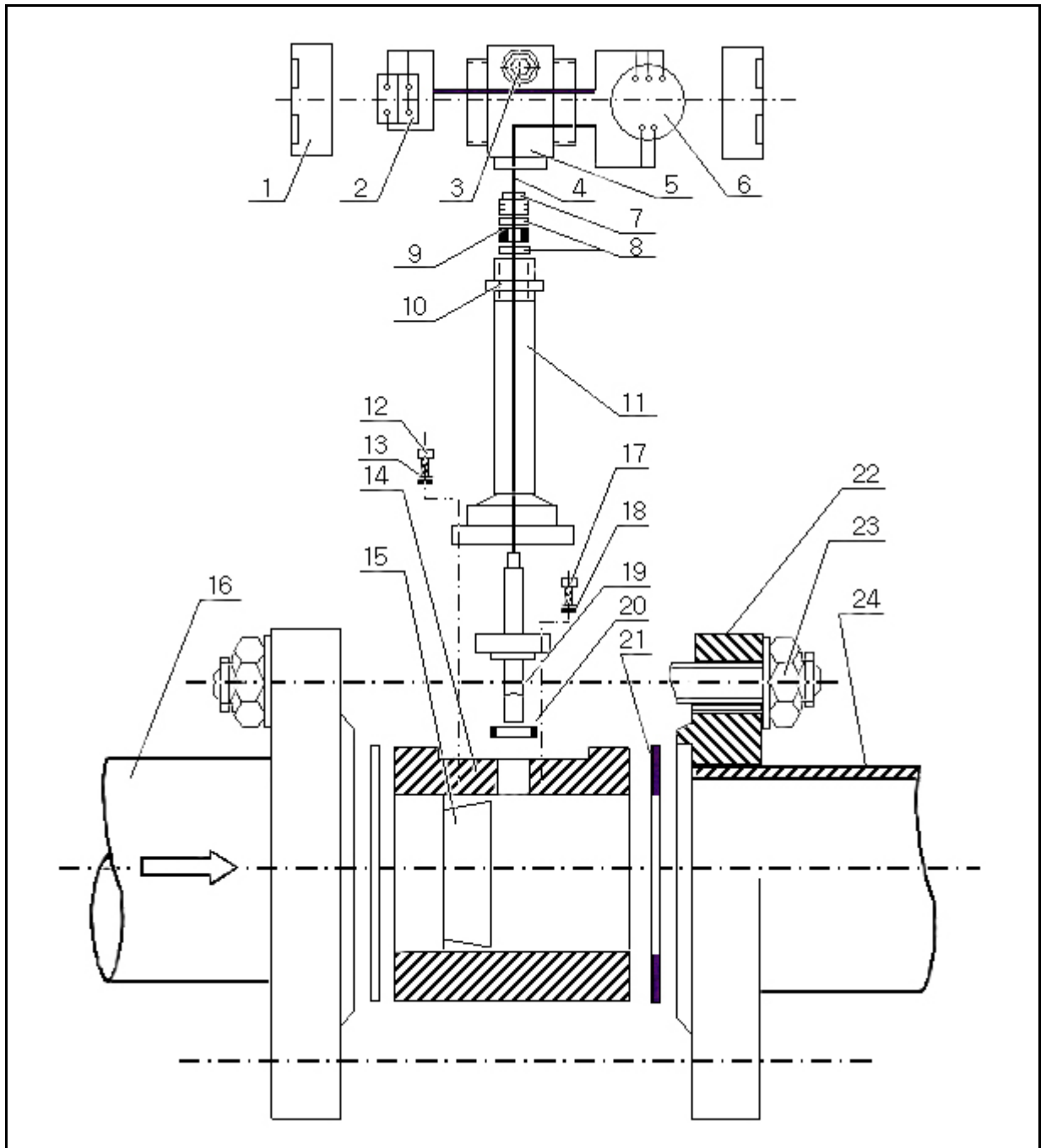

Figure 2-2. Flow meter structure drawing

1. Lid, 2. Outside wire terminal, 3. Outside wire socket hole, 4. Detector wire, 5. Amp case, 6. Amp circuit boards, 7. Tight bolt, 8. Steel washer, 9. Rubber sealing washer, 10. Tight nut, 11. Support probe, 12. M6 six angles bolt, 13. Washer $\phi 6$, 14. Main body, 15. Vortex generator(Δ column or T type), 16. Upstream pipe, 17. M5 six angles bolt, 18. Washer $\phi 5$, 19. detector, 20. Sealing washer, 21. Asbestos rubber, 22. Flange, 23. Dual head bolt, nut 및 nut washer, 24. Downstream pipe

Flow meter Size (Insert)

Table 3. Flow meter Size(H: mm)

DN(mm)	H(mm)	
	Non ball valve	Ball valve
250	~600	~825
300		
350	~650	~875
400		
500	~750	~975
600		
700	~850	~1075
800		
900	~950	~1175
1000		

Figure 2-3. Flow meter Size

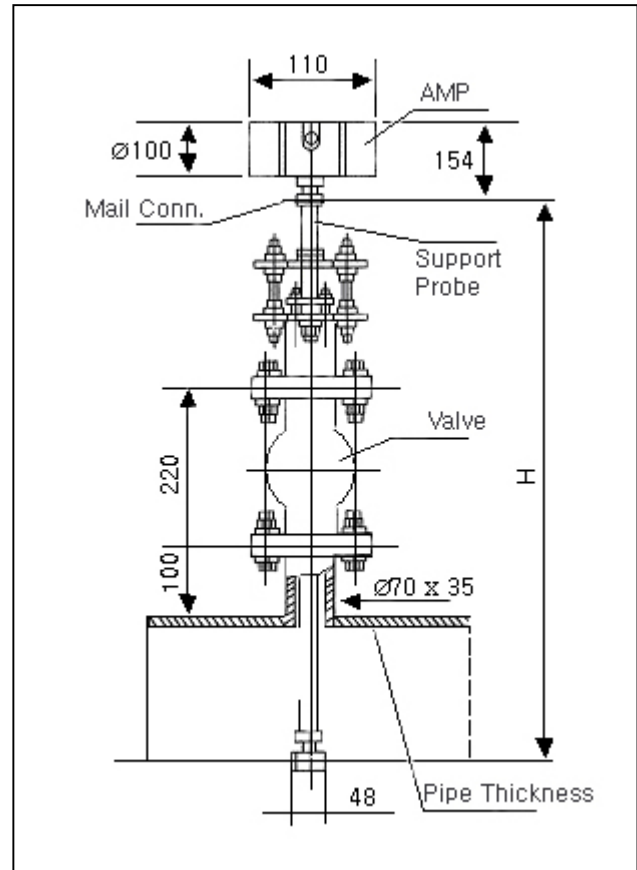

Chapter 3. Installation and electric wiring

Fittings

The output of VFM 8300 stress type vortex flow sensor uses both voltage (three-wire) pulse signals and totalize flow rate meter to measure flow rate. The XSJ/XSJB type totalize flow rate meter we recommend can be used with VFM 8300 type vortex flow sensor. You can refer to the manual provided separately for the specifications of the totalize meter. You can also contact the company for detailed information.

Installation

1. Installation select of site

- A. Ambient Temp. : The operating temperature of the sensor must be between -40°C and $+55^{\circ}\text{C}$.
When heat generated by manufacturing equipment exceeds $+55^{\circ}\text{C}$, heat insulation and ventilation must be set.
- B. Ambient Air : The flow meter must not be installed in a gas environment. If you have to install the meter in a erosive gas environment, you must install a ventilation system.
- C. Vibration and shock : The structure of the flow meter must be robust and must not be damaged by vibration. Vibration is generated with noise signals. The flow meter is resistant to vibration and shock. When the flow velocity is low, the noise signals are larger than the flow signals and generate an error in flow rate measuring.
The flow meter must be installed in a place where vibration and shock are minimal.
The installation location must be lower then 5 to 20Hz in vibration frequency.
When a vibration acceleration is $\leq 1g$, you must install a device absorbing vibration.
- D. Others : There must be enough space for installation of the flow meter. When the flow meter is installed high, a worktable is required for convenience of installation and repair. It must be near for except repair examination convenience AC220V power supply concert for measurement meter.

2. Piping installation and requirement

- A. There must be an enough duct part on the upstream and downstream side of the flow meter.
You can refer to the table 6 for length of the duct.
- B. Upstream and downstream pipelines must be parallel to length of the specified duct. You must avoid installing the flow meter on the lower part of the control valve and the half open valve so that the measured fluid can be filled completely.
You must avoid installing the flow meter on the back side of the pipeline.
- C. The flow meter can be installed vertically, horizontally or in any requested angle, and the direction of fluid must be bottom up.
- D. You must install the pressure and temperature-measuring point near the flow meter.
The temperature-measuring point is usually set to 1D of the sensor, and the temperature point to 5D of the sensor.

3. Vortex installation of flow meter

This flow meter and relevant total meter must be consisted, and take care. lower part item necessarily when establish to vortex flowmeter's basis.

- A. The fluid direction of the measured object must coincide with the arrow of the flow rate direction indicated on the main body.
- B. When installing the meter in a wafer type, you must prevent the seal pad from going into the pipeline. You can refer to the figure 3-1 and the table 4 and 5 for the size of the flange and the length of the bolt.
- C. The integrated flow rate meter using with the sensor must be installed on the measuring instrument board, or you must use a separate box.

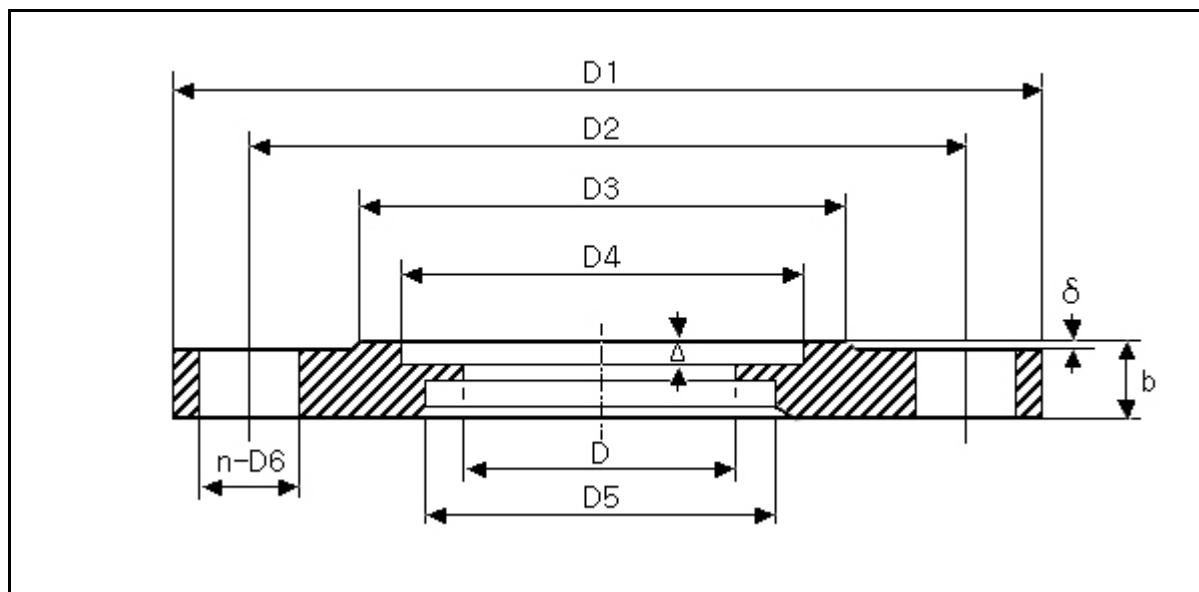

Figure 3-1. Flange Size

Table 4. PN2.5Mpa Saddle flange and dual head bolt size table (size unit : mm)

Standard	D	D1	D2	D3	D4	D5	D6	n	δ	b	Dual head bolt Standard = bolt outer Diameter x thread length x bolt length
DN25	25	145	110	85	77	33	18	4	2	18	M16 x 35 x 165
40	39	145	110	85	77	46	18	4	3	18	M16 x 35 x 165
50	49	160	125	100	87	58	18	4	3	20	M16 x 35 x 165
65	64	180	145	120	103	74	18	8	3	22	M16 x 35 x 165
80	79	195	160	135	113	90	18	8	3	22	M16 x 35 x 165
100	99	230	190	160	133	109	23	8	3	24	M20 x 35 x 180
125	125	270	220	188	176	134	25	8	3	26	M22 x 40 x 190
150	149	300	250	218	203	161	25	8	3	28	M22 x 40 x 190
200	207	360	310	278	259	221	25	12	3	30	M22 x 40 x 210
250	259	425	370	332	312	275	30	12	3	32	M27 x 50 x 240
300	309	485	430	390	328	328	30	16	4	36	M27 x 50 x 270

Table 5. P_N4.0Mpa Saddle flange and dual head bolt nut size table (size unit : mm)

Standard	D	D1	D2	D3	D4	D5	D6	n	δ	b	Dual head Standard = bolt outer Diameter x thread length x bolt length
DN25	25	145	110	85	77	33	18	4	2	18	M16 x 20 x 165
40	39	145	110	85	77	46	18	4	3	18	M16 x 25 x 165
50	49	160	125	100	87	58	18	4	3	20	M16 x 25 x 165
65	64	180	145	120	103	74	18	8	3	22	M16 x 25 x 165
80	79	195	160	135	113	90	18	8	3	24	M16 x 25 x 170
100	99	230	190	160	133	110	23	8	3	26	M20 x 30 x 180
125	125	270	220	184	176	140	27	8	3	28	M24 x 35 x 190
150	149	300	250	218	203	161	27	8	3	30	M24 x 35 x 190
200	207	375	320	282	259	222	30	12	3	38	M27 x 35 x 240
250	259	445	385	345	312	278	34	12	3	42	M30 x 40 x 270
300	309	510	450	408	363	330	34	16	4	46	M30 x 40 x 290

Basic piping drawing

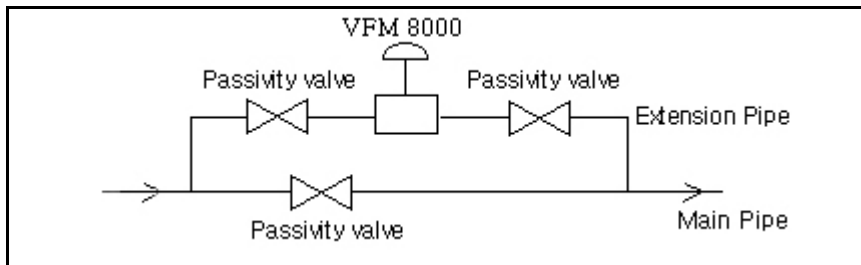

Figure 3-2. By-Pass basic piping

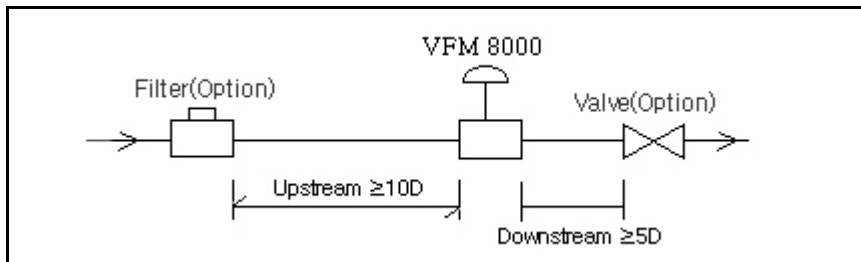

Figure 3-3. Where flow straightened is used

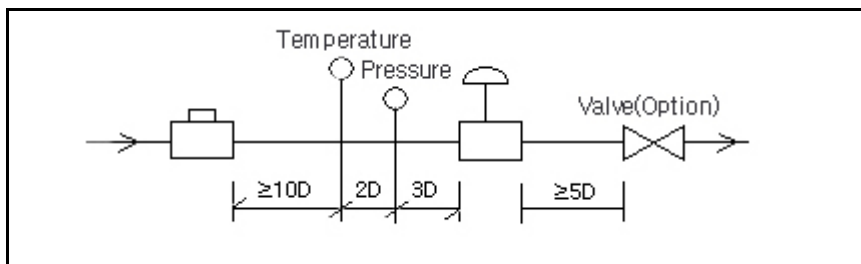

Figure 3-4. Pressure gage & Thermometer Installation

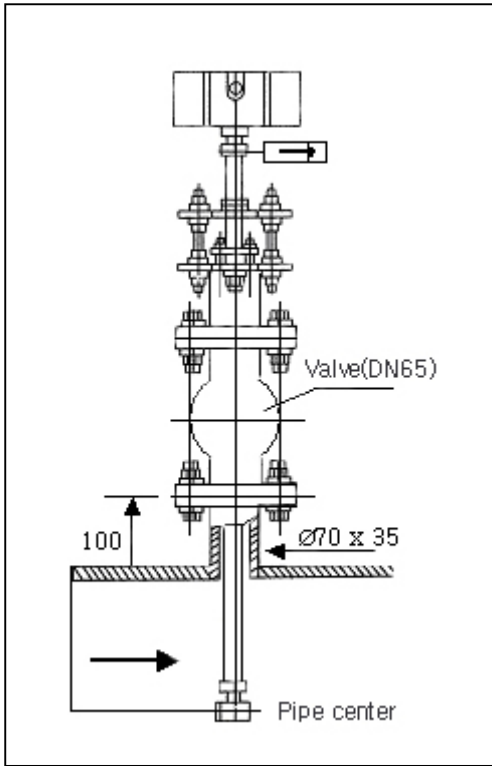

Figure 3-5. Insert type installation drawing

Table 6. Up & Down Stream Requirements

Intuition part (D Pipe inside)		
Pipe condition	Upstream	Downstream
Contraction duct whole open gate valve	15D	5D
Half open gate valve	50D	5D
90° quarter bend	20D	5D
two 90° quarter bend in one plain	25D	5D
90° quarter bend in different plain	40D	5D
Reducing pipe	10D	3D

Wire connection

1. The pipe, amp and case used to install the sensor must be properly ground-connected.
(Ground resistance 10Ω below)
2. You must use 24V DC power and three-wire connection when connecting with this flow meter or an XSJ/XSJB-type totalize flow rate meter we recommend.
3. The flow meter can be connected directly with the computer, and you can specify this type of connection when ordering the product.
When using this directly-connected computer, you must use three-wire connection and 24VDC and 30mA power with the sensor. The sensor outputs 5V(PP) voltage pulse signals to the computer.
4. The length of wiring between the flow meter and the totalize flow rate meter must be less than 200m.
When the length of transmission is over 200m, you must conduct a test after connection wire so that attenuation of circuits and noise of wire are not be affected by the normal measuring of the flow meter.

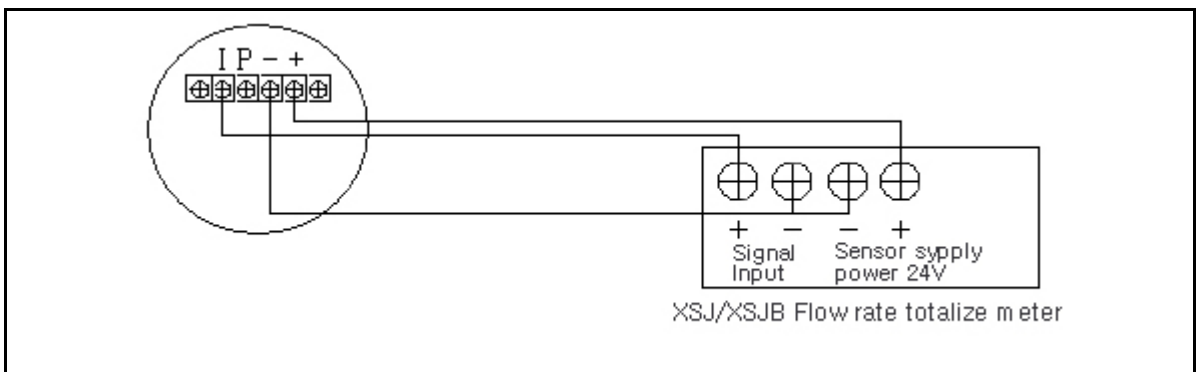

Figure 3-6. VFM 8300 and XSJ/XSJB wiring connection

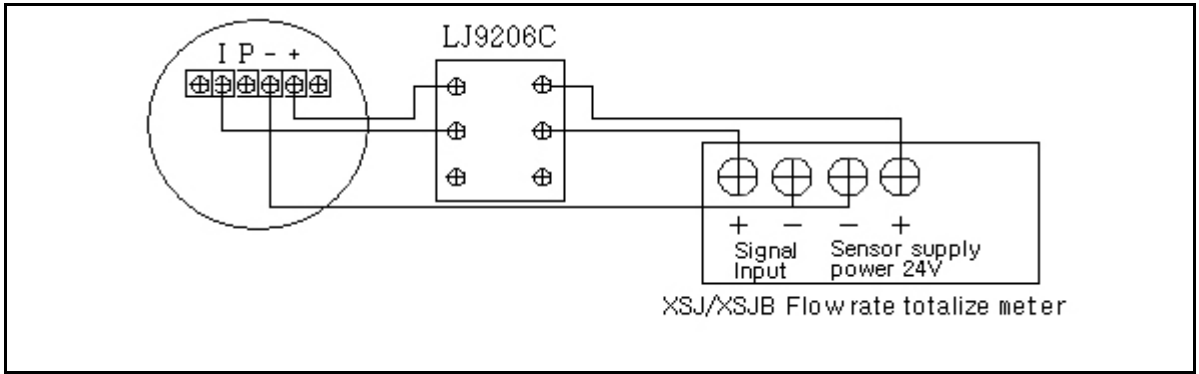

Figure 3-7. VFM 8300 Series Explosion place wiring connection

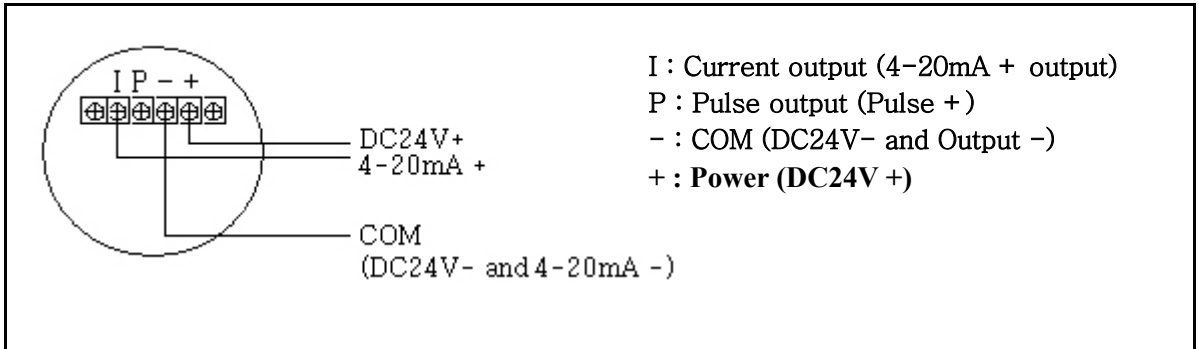

Figure 3-8. VFM 8300 Series wiring Terminal drawing

※ For other measuring instruments and wiring, you can refer to explanation of machine installation.

Chapter 4. Installation test and adjustment

1. Static operating of sensor Amp point table 6 reference.

Amp static working point (V. DC)

Power	T01 collector	DZ2	TP1	TP2	TP3	Output
24	21 ~ 22	6.8	4.5 ~ 5	1	4.5 ~ 5	0

2. Meter constant of flow sensor.

Flow sensor is corrected before shipment, and the constant for every sensor is specified in the ex-factory certificate.

In standard condition(P=101.3KPa, t=20°C), when 1-liter volume flow rate passes the sensor, the output is 1 pulse. When measured fluid is different or when flow rate unit is different, the constant of the flow sensor changes, and needs to be revised and corrected. Details are as follows.

- (1). The size of measured pipe and the generator changes depending on changes in temperature of the measured fluid. There is a significant difference between the content of the flowrate sensor and the revised value in room temperature, so you need to revise the content of the flow meter.

Revise K_T Factor $K_T = 1 - 4.8 \times 10^{-5} \times (t - 20)$

In t that measurement medium temperature, °C

- (2). When the unit of the flowrate is required because measured fluids are different.

This time, must convert flowrate sensor's constant. Specific substance is as following.

- A. Liquid measurement flowrate unit : m^3 , After revise constant;

$$K_a = K_T \cdot K \times 10^3 \dots\dots\dots (a)$$

- B. Steam measurement flowrate unit : kg, After revise constant;

$$K_b = K_T \cdot \frac{1}{P} \cdot K \times 10^3 \dots\dots\dots (b)$$

- C. When measuring gas, the indicated value on the measuring instrument must be changed to the flow rate in standard condition(P=101.3KPa, t=20°C).

The unit of the flow rate is $m^3(Nm^3)$, and the gauge constant after revision must be;

$$K_c = K_T \cdot \frac{0.1013}{0.1013 + P} \cdot \frac{273.15 + t}{273.15} \cdot K \times 10^3 \dots\dots\dots (c)$$

a, b, c formula:

K_a -- After revise meter constant(pulse number/ m^3)

K_b -- After revise meter constant(pulse number/kg)

K_c -- After revise meter constant(pulse number/ Nm^3)

K -- ex-factory installation constant of measuring instrument(pulse number/liter)

p -- density of steam depending on usage conditions of the measuring instrument(kg/ m^3)

P -- atmospheric pressure of gas depending on usage conditions of the measuring instrument(MPa)

T -- temperature of gas depending on usage conditions of the measuring instrument(°C)

After calculating the gauge constant based on the above a, b and c, the constant can be used with the totalize flow rate meter (refer to the manual of the totalized flow rate meter for how to use).

You can also get the value indicating the accumulated flow rate of a different measuring unit. When using the gauge constant, you can choose one among the above methods. After you send the basic specs including the range of flow rate, the manufacturer will ship the product accordingly. When a user changes the conditions of use after ordering the product (for example, the meter was originally intended to use for measuring air, but it was later changed to be used for measuring of steam), you must calculate the gauge constant by employing the above method.

3. Sensitivity adjusting

Sensitivity adjustment controls vibration and other noise. It prevents malfunctioning of signals when there is too much vibration, and improves accuracy of the flow rate.

Sensitivity adjust has ex-factory settings.

It is adjusted for the following reasons:

- (1). To ensure that there are quality vortex signals unaffected by regular noise of an electric machine in usage conditions of the flow meter
- (2). To maintain intensity of vortex signals and consistency and evenness of circuit pulse signals; and prevents omission of signals and multi-triggered signals. Waveform of each measuring point is as follows.

Amp normal waveform of each measurement point

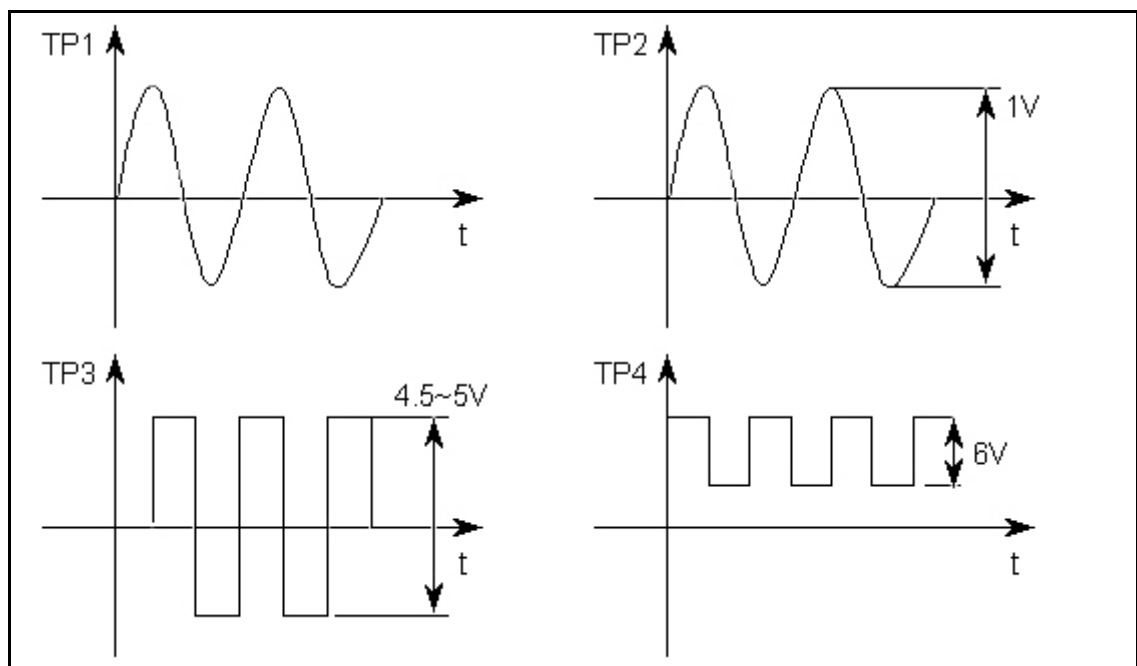

Figure 4-1. Amp each measurement point normal waveform

If there is no problem in the section (1), the waveform of signals measured in the Amp measuring point TP1 must be regular (signals can be overlapped slightly), and signal frequencies must be stable and change depending on changes in flow rate.

When TP1 signals are not normal, you must measure ground connection to improve electric interferences. In case of noise influence due to machine vibration, a problem with the center of the pipe during

installation or incorrect installation of the flange center, you must re-install the flow meter to increase volumes of signals. To achieve the goal of even consistent and even multi-output and zero output omission of pulse signals, dual oscilloscope is used to measure TP2 and TP3 waveforms at the same time.

Adjust gain W1 and output sensitivity.

It is recommended to conduct adjust when there is no flow rate.

When measuring TP3 waveform with the oscilloscope, you must open the front lid of the sensor.

When there is square waveform signals in zero flow rate, you must reduce sensitivity until zero pulse by adjusting the W2 in counter-clock direction.

When vibration is low and the flow velocity of the device is low, if sensitivity is too low, there can be no square waveform even when there is flow rate. In this case, adjust the W2 in clockwise direction when the flow rate of the pipe is minimal until normal pulse waveforms appear. By taking into account the two conditions mentioned above, you must adjust the W2 properly so that there is no pulse output when there is no flow rate, and that there is normal pulse output when the flow rate is minimal.

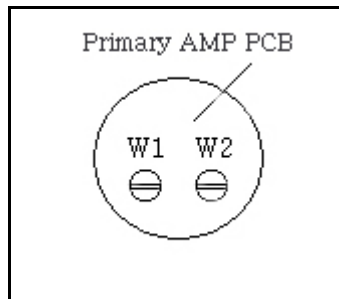

Chapter 5. Re-assemble

When repairing the flow meter or changing parts, refer to the drawing of the sensor structure (figure 2-2) and re-assemble the product in the following order.

1. Sensor Amp re-assemble

- (1). Power Off
- (2). Open the lid on the side of the inspection amp.
- (3). Release the screw used for fixing cable on the panel of the amp terminal, and pull out the cable.
Then, separate 2 signal input lines, 2 signal output lines and 1 ground connection line.
- (4). The Amp it releases 3 fixation screws and it pulls out the Amp circuit board.
- (5). When assembling the parts again, connect the cable with the wiring terminal and tighten the screw. Then, fix the 3 screws of the amp circuit board to the installation holes.

2. Sensor inspection separation

Installation of the inspection sensor: When the sensor is short with the case (When resistance between ground connections is $<1M\Omega$) or the sensor is damaged to have no signal output, you must replace sensors.

Sensor replace order :

- (1). Remove the sensor inspection amp in the above sequence.
- (2). Release the inside hexagon screw by using the M4 wrench. 11 (support probe)
- (3). Remove the tight press bolt (7), steel washer (8) and rubber seal gasket (9).
- (4). Release the inside hexagon screw by using the M6 wrench to separate the support probe and the main body.
- (5). Pull out the sensor by releasing the inside hexagon wrench (17) with the M5 wrench.
- (6). You can follow the above step reversely when installing the parts again.
 - A. The sensor gasket must be replaced with a new one.
 - B. The location fixing pin on the sensor must be aligned correctly with the hole.
 - C. The sensor fixing screw must be fixed evenly. The end of the sensor and the back side of the generator (tripod) must be on the same axis.
 - D. After assembly, the sensor and the sealed part of the main body must not be leaked (Use pressure pump for measuring pressure. The test pressure must be 1.5 times of the pressure of LCD).

Chapter 6. Troubleshooting and Repair

1. For precise use of the flow rate sensor, the measured fluid must be single fluid.
 Small amounts of vapor bubbles and foreign materials are allowed for liquid, but they must not exceed 15% of the main liquid.
 When there are too much foreign substance in measured fluid, it is recommended that you wash the passage area of the flow rate regularly to have good measuring results.
2. The reason why the flow rate sensor is not precise is malfunctioning of the sensor, a problem with the totalized flow rate meter, a problem with the computer or field conditions from the pipe.
 To analyze the cause of malfunction, you must examine the system entirely.
3. Refer to the below table 7 for how to check and deal with malfunctioning directly related to the sensor.

Breakdown phenomenon	Possibility cause and processing method
After connecting power and inspecting the amp, when pulse signal output is incorrect:	1. There is no flowrate running in the pipeline or there is too low rate. 2. Power of the Amp is not correct or parts are malfunctioning 3. The amp gain is too low or the trigger sensitivity is too low. You need to adjust the W1 or the W2 properly.
When there is no flowrate running in the pipeline, if there is sensor signal output:	1. Ground connection is incorrect. Noise is running in. 2. There is too much vibration in the pipeline. 3. The amp gain is too high or the trigger sensitivity is too high. You need to adjust the W1 or the W2 properly.
When the flow rate value is too high or too low, or the value fluctuates:	1. Installation is incorrect. 2. The adjustment of the amp trigger sensitivity gain is not proper. You need to adjust the W1 or the W2 properly. 3. The factor input of the display gauge is incorrect.

Table 7. Breakdown phenomenon and processing method

4. Order requirement
 When ordering the product, the user must present the following items to select a correct type and specs of the flow sensor.
 - A. Pipe Size : Pipe Outer x Pipe thickness(mm)
 - B. Measurement fluid name :
 - C. Maximum flowrate and Minimum flowrate . (kg/h, at m³/h) :
 - D. Work pressure (MPa) :
 - E. Whether need establishment Flange, state of intuition department.

ientek Co., Ltd.

Factor 2 (P)153-803

Daeryung Technotown 5th #407 493, Gasan-dong Gumcheon-Gu, Seoul, Korea
 TEL : +82-2-2107-7999 FAX : +82-2-2107-7990

Head Office & Factory 1 (P) 425-791

4th Engineering B/D Ansan Technopark #401 1271, Sa 1-dong, Ansan, Kyonggi-do, Korea
 TEL: +82-31-416-2228, FAX : +82-31-416-2338
[http:// www.flowmeter.co.kr](http://www.flowmeter.co.kr) , E-mail : master@flowcountry.com

Appendix parameters of vortex flow meter with different caliber

Size	Φ20	Φ25	Φ40	Φ50	Φ65	Φ80	Φ100	Φ125	Φ150	Φ200	Φ250	Φ300
d	6	7	11.2	14	18.2	22.4	28	35	42	56	70	84
K	140	72	17.5	9	4.5	2.15	1.15	0.575	0.425	0.14	0.072	0.042
	157	79	19.2	9.9	4.7	2.4	1.24	0.63	0.355	0.154	0.078	0.046
f _{steam}	230	100	50	30	27	22	15	10	8	6	5	4
	3489	2200	1125	945	1306	645	460	350	285	225	185	155
f _{gas}	120	90	40	25	20	12	8	7	6	4	3	2
	1745	1300	900	850	1045	330	320	285	185	135	120	120
f _{liquid}	12	8	4	2.5	1.5	1.2	1.0	0.8	0.6	0.4	0.4	0.4
	437	345	150	135	131	80	65	55	45	40	40	38
Q _{steam}	2.5	5	10	15	30	35	50	70	90	200	300	500
	80	120	300	150	1000	1200	2000	3000	4500	7500	12000	18000
Q _{gas}	3	4	7	10	15	20	35	42	50	120	150	200
	40	80	250	400	800	1000	1500	2500	3500	6500	8000	12000
Q _{liquid}	0.3	0.4	0.6	1	1.5	2	3	5	8	15	25	40
	10	16	30	50	100	130	200	300	450	800	1200	2000

Sr--- Strouhal number ; d---cylinder front width (mm) ;
 K---coefficient (1/L) ; Q---volume flow rate (m³/h) ;
 f---karman vortex frequency (Hz) , upper and lower limit error range in ±5%
 F----St*V/d ; K=N/Q ; V=Q/A ; M=P×Q ; Q=3600f/X

Use description

1. Key board and display

F	6bit instant flowrate
Fr	6bit frequency measure value
PE	6bit current output value
U	6bit flowrate Factor
dEn	6bit fluid density
FH	6bit flow range
FL	Small signal cut data
XXXXXXXXXX	10bit Total flowrate(Integrated flowrate)
Display	Display data

Warning : There is this parameter to PE, FH remote signal output.

When dEn is remote output, decrease coefficient display, fluid density be.

2. Key board operation

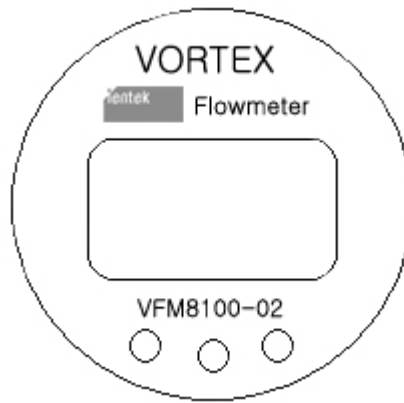

K1 K2 K3

3 function key is display by K1, K2, K3 with upside picture. Operation is same with lower part.

K1	K2	K3
Totalize	Instant	Setup
Cyclic shift	Return	(Enter)

- (1) When do Operation K1, K2, K3 each Totalize and instant setup key be.
- (2) In Setup state K1, K2, K3 each totalize and instant key that do ENTER be.
- (3) If press totalize key once in operation state, 10bit's totalize value is displayed.
If press Instant key once, instant flowrate is displayed.
If press Setup key once, with instant flowrate, frequency output current, flowrate, flowrate Factor, dE value, flowrate range, minute flowrate upper limit cut sequentially confirmation.
- (4) First, press K3 Key, and at the same time make off K2 in setup state repeatedly.
This time, flowrate Factor, dEn vlaue, flowrate range, minute flowrate value cut etc. setup possible.
If press K3 key, sequentially U, dEn, FH, FL etc. display about data that is done, and is marked present revise.
Ex: Setup density 12345, first, go to set up menu, and press the 'K3' key to make display 'dEn-XXXXXX', (the top is flash) press the 'K2' key to make display '1' at the first row, press the 'K1' key one more time, and move to the second row.(the second row is flash), press the 'K2' key to make display '2' at the second row, setup to the last row one after the other.(single decimal point)
after checking the numerical errors, if there is no error, check the 'K3'key and setup parameter at once.
After completing all the parameter setup, press the 'K3' key and then press the 'K2' key, it shows the install state in the set up condition and enter to condition of display.
- (5) Battery static totalize flowrate zero reset : In Setup state Un clause after install by 004321 enter key press.
- (6) Current remote type totalize flowrate zero reset. : If K1 key presses series 5 times, zero reset do.
- (7) Code switch use method in Amp board. : Other code switch number of times according to size and fluid.

Gaseous state

Size	25	40	50	80	100	125	150	200	250	300
SW1	1, 5	2, 6	2, 6	2, 6	2, 6	2, 6	2, 6	3, 7	3, 7	3, 7
SW2	1	2	2	3	1, 3	2, 3	4	4	4	4
SW3	1	2	2	3	1, 3	4	5	4, 5	6	6

Liquid state

Size	25	40	50	80	100	125	150	200	250	300
SW1	3, 7	3, 7	3, 7	3, 7	3, 7	3, 7	3, 7	3, 7	4, 8	4, 8
SW2	5	5	6	6	6	6	6	7	7	7, 8
SW3	4	4, 5	6	7	7	7	8	7, 8	7, 8	7, 8