

# Ultrasonic Level Transmitter (ULT)

## Instruction manual



Ultrasonic Level Transmitter

### **ientek Co., Ltd.**

**Factor 2 (P)153-803**

Daeryung Technotown V #407 493, Gasan-dong  
Gumcheon-Gu Seoul, Korea

TEL : +82 2 2107 7999 FAX : +82 2 2107 7990

**Head Office & Factory 1 (P) 425-791**

4th Engineering B/D Ansan Technopark #401  
1271, Sa 1-dong, Ansan, Kyonggi-do, Korea

TEL: +82 31 416-2228 FAX : +82 31 416-2338

http:// [www.flowmeter.com](http://www.flowmeter.com) , E-mail : [master@flowcountry.com](mailto:master@flowcountry.com)

**ientek Co., Ltd.**

OE-0  
2007.07.13

# TABLE OF CONTENTS

Preface .....	2
Warnings and Cautions .....	2
Caution .....	2
Information .....	2
<b>Chapter I . SUMMARY</b>	
SUMMARY .....	3
Use .....	3
Applications .....	3
Features .....	3
Measuring range .....	3
MAKE UP & THE STRUCTURE .....	3
Whole structure .....	3
The panel of electronic unit .....	4
Terminal block diagram .....	4
TECHNOLOGICAL PRINCIPLES .....	4
TECHNICAL SPECIFICATIONS .....	5
The crossing hole structure of installation with brackets .....	5
The external dimension of level meter .....	6
The external dimension of transmitter .....	6
<b>Chapter II . OPERATION SYSTEM</b>	
INSTRUMENT OF WORKING STATION AND OPERATION .....	7
Display modes .....	7
Button .....	7
Working state and setting up the parameter .....	7
Measure state & state of setting up the parameter .....	7
Measure State .....	7
State of setting up the parameter .....	8
Instrument checkout .....	9
INSTRUMENT INSTALLING .....	9
Installation demand .....	9
Wiring .....	11
Work after electrifying .....	11
<b>Chapter III . TROUBLE SHOOTING</b>	
DEALLING WITH TROUBLES .....	13

## Preface :

ientek Model : ULT Ultrasonic Level Transmitter offer advanced for today's' demanding level measurement needs from customer.

This device provide maximum benefits superior results and it has carefully designed instructing manual, And Also,

The device ientek ultrasonic level transmitter is not liable for any damage or personal injury.

Whatsoever resulting from the use of ientek instrument standard ultrasonic level transmitter.



Warning 1 : When wiring or connecting this unit to a power source, only qualities personal should be installed and wired.

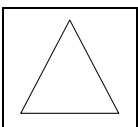

Warning 2 : Always main power-off before install and remove or disassembly ultrasonic level transmitter unit

Caution : During operation, please wait 1 minute as stare-up with stability.

## Caution :

- ① Always fully qualified personal should be performed maintenance or trouble shooting procedures.
- ② Printed circuit boards will be sensitive to electrostatic discharge, to avoid damaging boards follow these precautions to minimize the risk of damage.
  - Before handling the assembly, discharge your body touching a grounded
  - When possible, use grounded electrostatic discharge wise straps when handling sensitive components.

Caution : For all installations of Level meter standard industrial wiring practices apply.

Caution : Be sure that your Level meter is equipped for the correct input power by checking the label on the outside of the unit and this manual wiring diagram.

Caution : Before powering-up for the first time, check all wiring to ensure.

Caution : Before attempting any maintenance make sure there is no pressure in the tank or vessel and must be carried out with the power-off

## Information

ientek Ultrasonic Level Transmitter Model: ULT is designed to accurately measure and control flows of process liquids.

When receiving a ientek Level meter, carefully check the outside packing carton or damage incurred in shipment.

If the carton is damaged, notify the local carrier and submit a report to the ientek Factory No2.

(See manual surface) Addressing Information.

Do not return any equipment to the factory without first contacting ientek.

If you encounter a problem with your Applications,

for each step : Installation / Wiring

Operation

Set up procedure

Verify that with ientek

We are working 09:00 AM to 18:00 PM Monday to Saturday in a Week.

# Chapter I . SUMMARY

## 1. SUMMARY

**Use:** Measurement for the liquid location or the material location.

**Applications:** It can guarantee the ultrasonic wave to travel to the occasion of measured liquid or material surface effectively. For instance: Store pot, material trough, pond, well, ditch, measuring case, granary, material storehouse, etc..

**Features:**

- Divide design, installed conveniently
- 4 wire transmitter standard, guarantee that the powerful sound wave is launched, that measurement is steady and reliable
- Protected in the excessive voltage and current, protected in the thunder and lightning
- The big show window of LCD is easy to debug and observe
- Intellectual signal treatment technology, guarantee that the instrument meets various kinds of operating occasion
- All plastic outer cover (IP67), airproof and alkali-resisting, meet the abominable environment
- Flexible support or flange are used to install

**Measuring range:**

**Liquid level :** 4m, 6m, 8m, 10m, 15m, 20m, 30m

**Solid level :** 3m, 5m, 7m, 10m, 15m

When using to measuring solid level, the most energy of ultrasonic is absorbed or scattered by solid level, so the back wave is very little, the valid measuring range of solid level is about 50% of liquid level. And the valid measuring range of solid level is determined by the installing location and nag

## 2. MAKE UP & THE STRUCTURE

**Whole structure:** There are three kinds of forms in level meter:



**Model: 4m, 6m, 8m**



**Model: 8m(A), 10m**



**Model: 15m, 20m, 30m**

### The panel of the electronic unit :

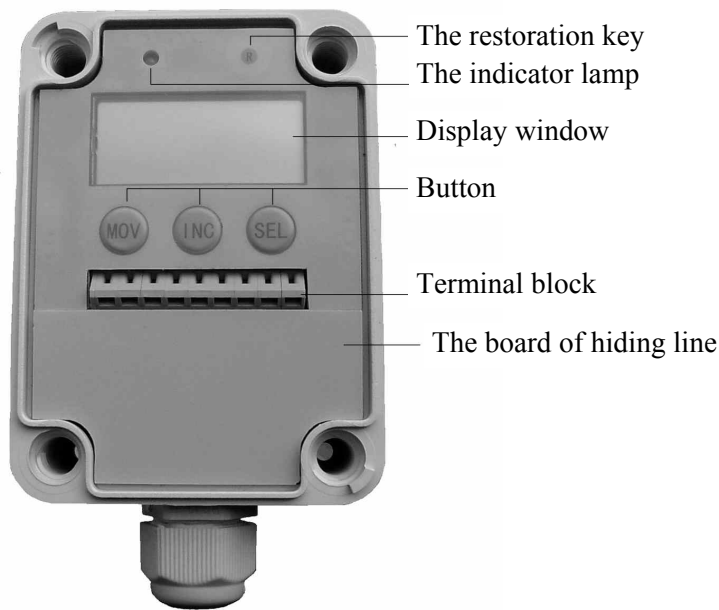

### Terminal block diagram :

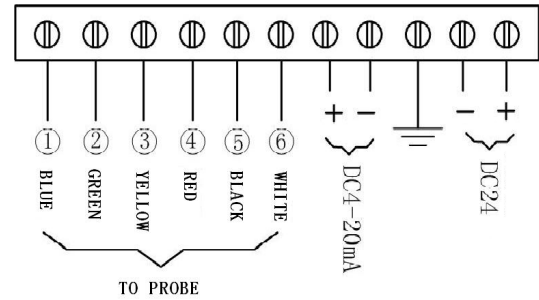

## 3. TECHNOLOGICAL PRINCIPLE

The level meter is composed with the designed in the integrative ultrasonic wave sensor and electronic unit.

The level meter installs on the top of the container, under the control of the electronic unit, the sensor and the launches a bunch of ultrasonic pulses to the things of tested.

Sound wave is reflected by object surface, parts of reflected return waves echo are received and change into the electric signal. The time of launching ultrasonic wave to receiving it again is direct ratio to the distance of sensor to the things of tested.

The electronic unit measures the time, and calculate out the distance examined according to the known velocity of sound.

Then draw the location value of things through subtraction operation.

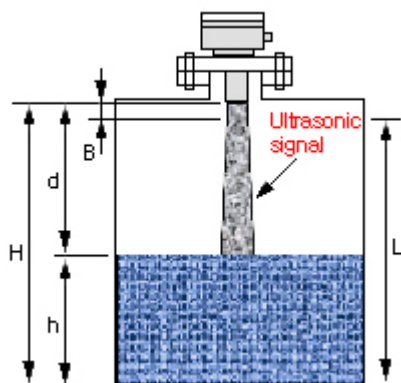

Symbol in the picture:

**B** : Blanking distance

**d** : Empty distance

**h** : Thing location

**H** : Installation height

**L** : Measuring range

$$h = H - d$$

### The sketch map of measuring the thing location

Ultrasonic wave spread speed among gas is influenced by gas temperature, when level meter works, it measures gas temperature needing, compensates for the velocity of sound, so as to ensure the precision of measuring.

While level meter launches the ultrasonic pulse, it can't measure the return waves at the same time. So one short distance down word from sensor is **blanking distance**.

If the supreme thing location examined enters the blanking distance, the instrument can't measure correctly, then error.

If needing we can count the level meter and increase to install.

## 4. TECHNOLOGICAL SPECIFICATION

### Measuring range :

Liquid	4.00m	6.00m	8.00m(A)	10.00m	15.00m	20.00m	30.00m
Solid			3.00m	4.00m	6.00m	10.00m	15.00m

### Blanking distance :

Measuring Range	4m	6m	8m(A)	10m	15m	20m	30m
Blanking distance	0.20m	0.25m	0.30m	0.40m	0.60m	0.80m	1.20m

**Accuracy :** 0.2% Full Span (In Air)

**Resolution ratio shown :** Measuring range: 4m, 6m, 8m: **1mm**

Measuring range: 8m(A), 10m, 15m, 20m, 30m: **1cm**

**Mode of indication :** 4 Digit LCD

**Output current :** 4~20mA

**Output load :** 0~500 Ω

**Output resolution ratio :** 0.03% Full Span

**Parameter setup :** 3 induction buttons (MOV, INC, SEL)

**Temperature range :** -40°C ~ +80°C

**Temperature compensation :** The whole range is automatic

**Pressure range :** ±0.1MP (Press definitely)

**Power supply :** AC220V ±20% 50mA

**Cable diameter :** Φ6~Φ12mm

**Single wire diameter :** Φ0.5~Φ1.78mm

**Cable Fix :** PG 13.5

**Beam angle :** 8°(3db) Measuring range 4m, 6m, 8m

5°(3db) Measuring range 8m(A), 10m, 15m, 20m, 30m

**Measure cycle :** 1 Second

**Crust material :** ABS

**Sensor material :** PVC

**Protect grade :** IP67

**Mode installation :** Flange or the support

**Flange standard of butt joint :** Measuring range 4m, 6m, 8m : Minimum DN65

Measuring range 8m(A), 10m : Minimum DN80

Measuring range 15m : Minimum DN150

Measuring range 15m, 20m, 30m : Minimum DN200

### The crossing hole structure of installation with brackets:

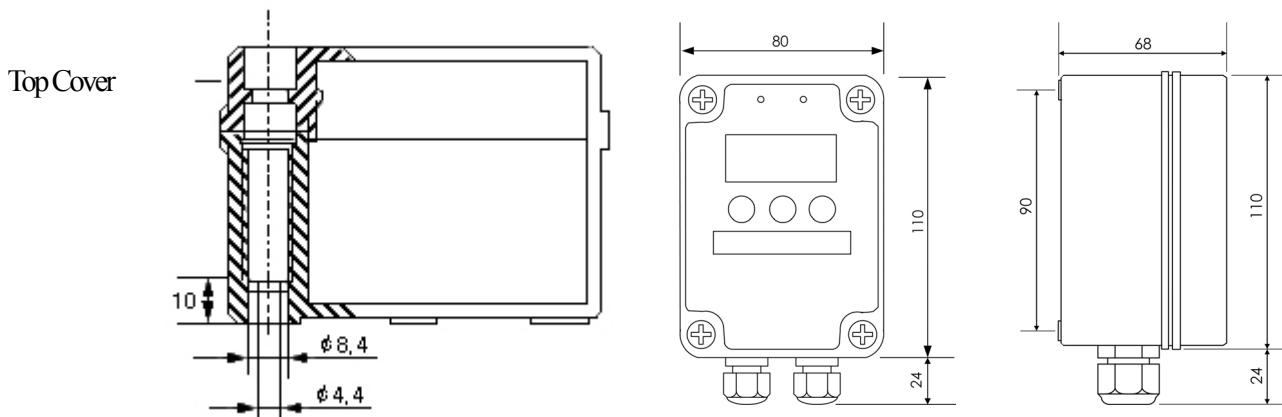

Should open the top cover while installing, then penetrate M4 regular screw or the bolt downwards.

**Cannula:** Using for Model 4m, 6m, 8m ultrasonic level meter, when installing at a flange or in a tube, the cannula must be fixed on the sensor. A screw thread is in the cannula, it can fix on the sensor directly:

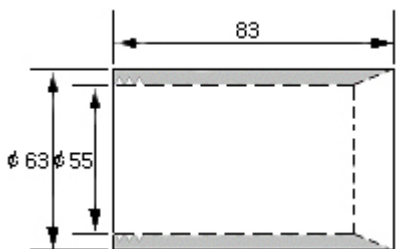

**The external dimension of level meter :**

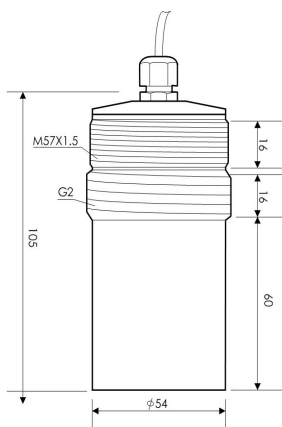

**Model: 4m, 6m, 8m**

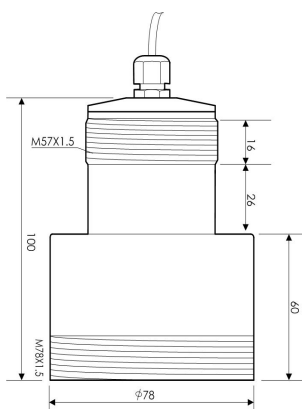

**Model: 8m(A), 10m**

**The external dimension of transmitter**

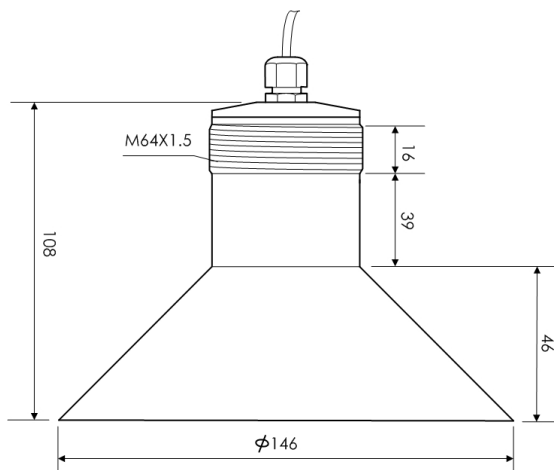

**The external dimension of probe : 15m**

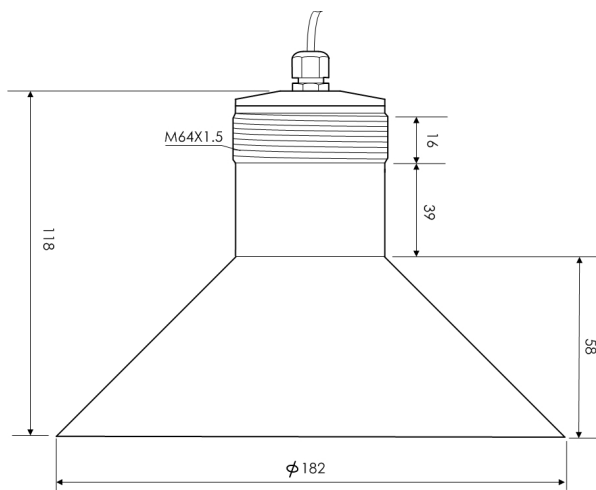

**The external dimension of probe: 20m, 30m**

# Chapter II . OPERATION SYSTEM

## 1. INSTRUMENT OF WORKING STATION AND OPRATION

**Display modes :** 4 digit LCD liquid crystal display

### Buttons

There are 4 keys on the instrument, the function as follows:

**SEL :** For choosing different display content or parameter.

**INC :** When setting up the parameter input a certain digit figure from 0 to 9 circulation change.

**MOV :** Choose a certain digit while setting up the parameter. When choosing this digit, this digit becomes dark, later pressed **INC** key and revised its value.

**R :** Press this key, the instrument is restored.

### Working state and setting up the parameter

The instrument has two kinds of working state:

#### Measure state & state of setting up the parameter

Pressing **SEL**, **MOV** key at the same time can be switched around.

#### Measure state

Measure state, instrument can make the thing location value, empty from value, temperature value shown by turns.

Press **SEL** key to choose. Give a demonstration as follows: (please pay attention to marking symbols)

Display Mode	LCD	LED
Thing Location Value	:3692	□ 3692
Empty From Value	:2586	□ 2586
Temperature Value	16.2	16.2

No matter what kinds of number value it will be shown, the current outputting of instrument is always the corresponding thing location value.

There is one getting green indicator lamp in the top of the instrument panel, once one second, indicate that having echo to be admitted arriving at.

The unit of the thing location value and the empty from value is meter(m ), the unit of temperature is degrees centigrade.

Pressing **SEL** and **MOV** keys at the same time, instrument can enter the state of the setting up parameters.

**The level meter shown thing location value first after started, restored or exit of parameter setting up.**

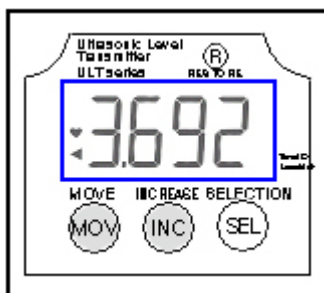

**The thing location value**

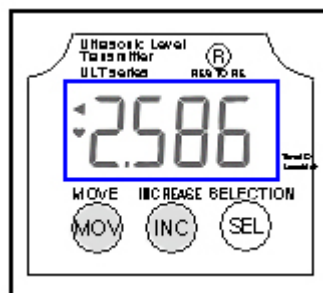

**The empty from value**

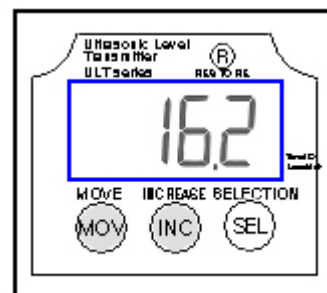

**The temperature value**

Press **SEL** key to choose display, make the thing location value, empty from value, temperature value shown by turns.

Leave off the key quickly after press down, instrument can showing by turns.

Alone press INC, MOV keys is invalidate.

Pressing SEL and MOV keys at the same time, instrument can enter the state of the setting up parameters.

### State of setting up the parameter

In this state, the instrument shows various kinds of parameters needing users to set up.

Press SEL key to choose. The content and sign give a demonstration as follows

Display Mode	LCD	LED
Installation Height	6.278	H 6.278
Measuring Range	6.000	L 6.000
Inside password	00	00

**Installation height:** The distance from launch surface of the sensor to the container bottom.

**Measuring range:** The maximum of the examined thing location, output the current of 20mA correspondingly.

**Inside password:** After inputting correct value, the instrument enters the state of the inside working parameter setting up.

Users needn't set up the numerical value, please don't enter the state of the inside working parameter setting. Should press SEL key and leave this parameter.

Or press SEL and MOV keys at the same time and withdraw the parameter setting.

Press SEL key and choose the parameter, press MOV and INC key to revise.

Should press SEL key once again after revising, in order to enable the instrument to store this parameter.

Pushing SEL and MOV keys at the same time can withdraw from the state of the parameter setting up, and store the parameters.

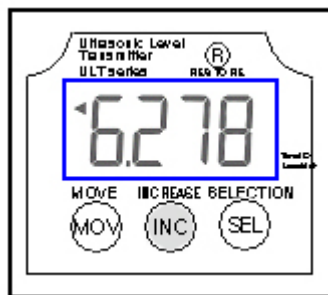

Pressing SEL and MOV keys at the same time, enter state of parameter.

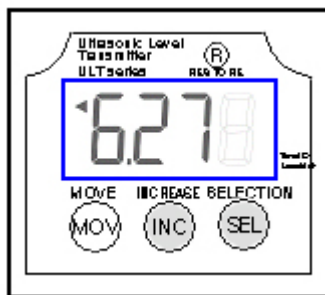

Press MOV choose the carry of parameters

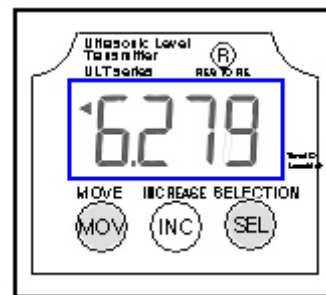

Press INC, to change the value.

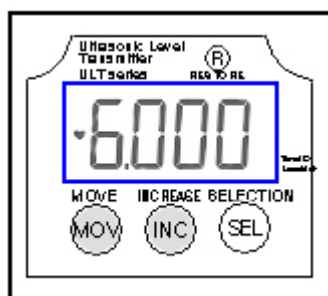

Press SEL key to store the previous parameters and enter next

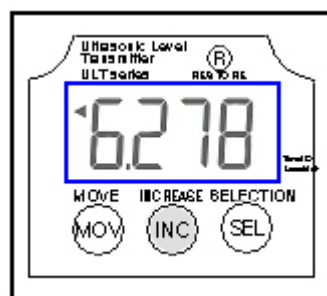

Pushing SEL and MOV keys at the same time with draw from the state of the parameter setting up

### Instrument checkout

Instrument can checkout aim at surface of wall.

But should pay attention to it, in order to improve stability of measuring.

In the instrument have inspect window, its collectivity extent is 1 meter (m), the mark out of the measuring window range, instrument needs a judgment course, So the measuring instance can't have break over 0.5m or instrument need time about 10s to feedback.

For the break from farness to near sometimes, instrument will appear Mistake.

But in fact measuring it is usually being less.

## 2. INSTRUMENT INSTALLING

**The rational installation of the instrument is the key to working reliably.**

The instrument install above container, launch surface of the sensor should point to the liquid surface or the material surface vertically.

If it is the airtight container, should adopt the flange type to install.

Other situations can install with the simple support.

Flange type installation should furnish the flange according to the instrument whorl size.

### Installation demand

When ultrasonic wave is launched, it will have a very small diffusion angle.

If have other object in the diffusion angle, ultrasonic wave will reflect, some measure error will appear when the reflection strong enough.

But velvet container can't reflect ultrasonic wave, send from above.

△ **Installation site far away from accidental container wall to try one's best, far away from the object that can stop sound wave of container such as escalator, transfusing mouth and blender etc..**

△ **Measuring range 4m, 6m, 8m as follows instance must use a Cannula outside of the sensor.**

1. At the place of container flange to install.
2. Install at the thicker floor slab hatch.
3. Along raise place of the container(pool) stomata to install.
4. Take the sensor in the circle tube to install.

△ **If it is the airtight container, the flange on the container should accord with the following demand :**

Mode	Demand
Measuring range 4m, 6m, 8m	Minimum 65mm inner diameter of the flange. Insure the inboard wall of nozzle smooth. And a <b>Cannula</b> must be used outside of the sensor at the same time.
Measuring range 8m(A), 10m	Minimum 80mm inner diameter of the flange, nozzle length should less than 150mm, insure the inboard wall of nozzle smooth, under along a smooth arc.
Measuring range 15m, 20m, 30m	Minimum 200mm inner diameter of the flange, flange nozzle length should less than 200mm. Measuring range 15m : Minimum 150mm inner diameter of the flange. Flange nozzle length should less than 150mm.

**Narrate:** When the sensor of measuring range 4m, 6m, 8m their side face closer comparatively to other object.

This object come into surrounding more to sensor, or the area is too big to the face of sensor, the instrument maybe become fake signal, So that the instrument can't natural work. with above-mentioned instance must install cannula on the sensor.

Showing as follows:

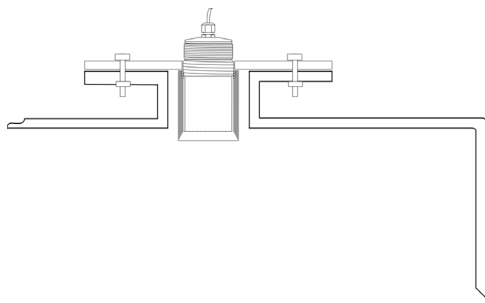

At the place of container flange to install.

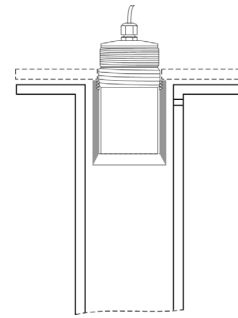

Take the sensor in the circle tube to install.

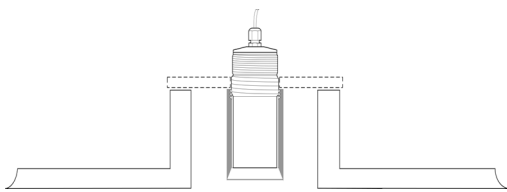

Along raise place of the container (Pool).

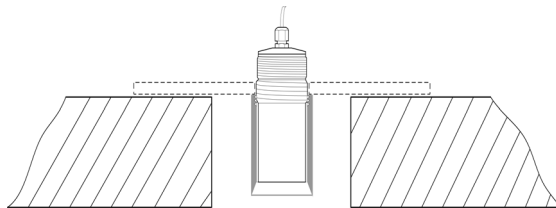

Install at the thicker floor slab hatch

Measuring range 4m, 6m, 8m level meter where need install cannula

△ Measuring range 15m, 20m, 30m level meter : when they are install at the flange on the container, at the thicker floor slab hatch, Along raise place of the container(pool) stomata, demand the highness or the thickness should less than the length of the sensor.

Showing as follows :

Right install mode

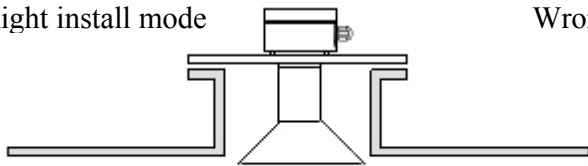

Sensor should put out

Wrong install mode

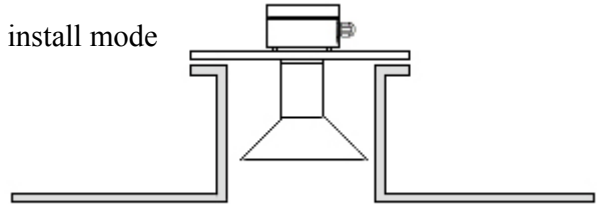

The front of the sensor should place at the tube

Simple method to deal whit.

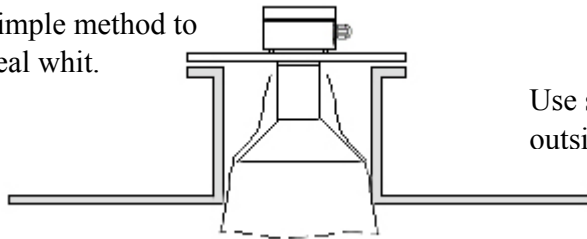

Use soft plastic Use soft plastic package the sensor outside until out of the tube needn't very order.

Standard disposal method: 1. Shorten the nozzle  
2. Lengthen the sensor

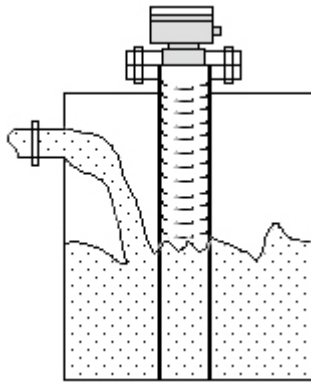

Join the plastic tube to level off measuring

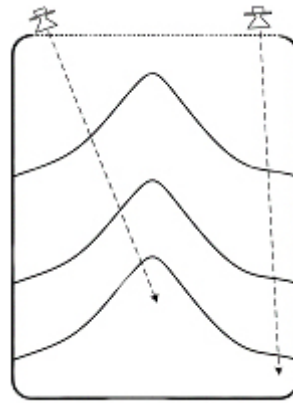

install position and angle, when measure material location

- △ If exist that the liquid fluctuate great, or having floaters, having objects that stops the sound wave etc., can insert a plastic tube to the container, make the sound wave spread in the plastic tube only, it is reliable to guarantee measurement steadily.

Demand the inner diameter of the plastic tube bigger than the outer diameter of the sensor. Inboard wall must be smooth, equal straight and no seam.

The plastic tube should be straight, one hole should be open in top and bottom, so as to ensure that it is the same to be in charge of the internal and external level Simultaneity, for measuring range 4m, 6m, 8m level meter, a Cannula must be used outside of the sensor.

- △ Launch surface of the level meter sensor should point to the liquid surface or the material surface vertically, should aim at goal as much as possible when installing when install to the cold area, should choose the lengthen sensor of the level meter.

The plastic make the sensor extend into the container, shun frost and lengthen sensor shun frost and icing.

How length need to lengthen, can confirm when subscribe for.

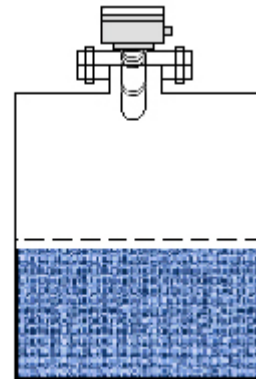

- △ Should guarantee the level not to enter the blanking distance at it can increase installation height if need.

When increase installation height, require that the inner wall of nozzle should be smooth, its inner diameter should smaller than container flange's inner diameter.

When the flange type installed, it should be a plastic material flange compounded for the sensor.

### Wiring:

Need to take off the hiding line board at the time of wiring, and emerges the whole terminal block. Wiring use “one” word screwdriver as following picture.

### Work After Electrifying:

Instrument show “HLUC” at first after electrify, show level value after a few seconds, indicator lamp glitter once every second at the same time.

What the instrument actual measured is the distance from sensor to the liquid or the material, later converted out the liquid location or material location value, it is very important to grasp this principle.

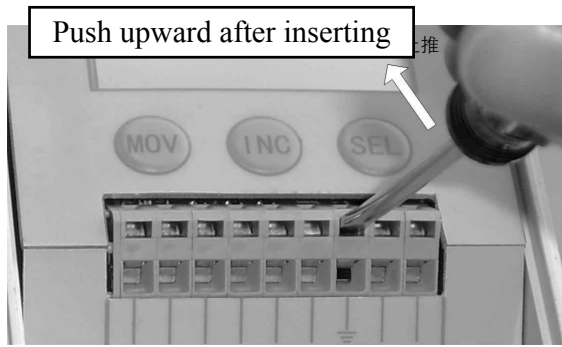

Press **SEL** key can look over measure distance value and temperature value.

Press **MOV** and **SEL** keys at the same time can enter parameter setting up state, after setting up installing height and measuring range, established upper limit and lower limit according to the need, then pressed **SEL** key once again.

Then press **MOV** and **SEL** keys at the same time and return to measure state.

The instrument will show correct level value, will output the correct current signal, the switch signal in the upper limit and lower limit.

If measurement is wrong, please refer to the next section that “Trouble Deal With”.

# Chapter III. TROUBLE SHOOTING

## DEALLING WITH TROUBLES

Trouble Phenomenon	Trouble Reason	Solution
The instrument does not show, and does not work	It is wrong to supply power Wiring mistake	Check DC24v supplies power is right or not Check wiring is right or not
The instrument showing, not working	Sensor has not aimed at the liquid or the material Fluctuating range is very great the liquid Do not level extremely the material There are thicker foams the liquid The container bottom is not the level after the supplies are emptied. Exceeding the Measuring Range	Adjust the sensor and aim at the liquid or the material Join a plastic tube to the container Use level meter of the greater measuring range Use level meter of the greater measuring range Resume working naturally after adding the liquid or the material Use level meter of the greater measuring range
The instrument shows the unstable or there are great deviations in measurement value.	The level enters the blanking distance Model 4m 6m level meter instilled on flange There are strong electromagnetisms interfered There are objects which stops the ultrasonic wave Have compounded the metal flange ring to sensor Touching with the metal on the sensor's launch surface or side face	Increase the installation height or prevent the level too high a <b>Cannula</b> must be used outside of the sensor Connect the earth or add the shielding for the level meter Change the installation site or join a plastic tube Use the plastic flange ring instead Use the rubber cushion to isolate from metal
The measure value has a small deviation all the time	The Installation height setting up has deviation There is a deviation all the time in distance measurement	Set up again The velocity of sound of gas changes, contact with producer.