

Features

Series 7260 is single-board, self-contained and state-of-the-art ultrasonic flow meter.

It has the notable characteristics of high precision, high reliability, high performance, low price etc..

Main features are

- The sensors being clamp-on type, there's no pressure loss. The sensors are easily mounted on the surface of the pipe without interrupting the flow for installation or maintenance.
- Built-in battery or DC power. (DC 15~24V)
- Using the most advanced direct-time-measuring method, the unit offers a signal resolution of 0.2ns. In addition, advanced data processing functions ensure series 7260 of high linearity.
- Signal outputs including current signal and RS-485;



7260

Description

When an ultrasonic wave travels in a liquid, the flow of the liquid will cause its speed to change.

When it travels in the flow direction, its speed increases and against it, it decreases. By measuring the difference in travel times between both directions, one can measure the flow speed.

As shown in Chart 1, a pair of sensors are mounted upstream and downstream on the surface of the pipe. Its mounting configuration can be 'Z' or 'V'. The time - difference of ultrasonic signals transmitted and received across upstream and downstream are calculated as below;

$$T_{UP} = \frac{MD / \cos\theta}{C_0 + V \sin\theta} \quad (1) \quad T_{DOWN} = \frac{MD / \cos\theta}{C_0 - V \sin\theta} \quad (2)$$

M - travel time D - inner diameter
 θ - transmit angle C_0 - fluid static sound velocity

T_{UP} - travel time of upstream signal

T_{DOWN} - travel time of downstream signal

ΔT - time difference as per equations (1) and (2), Using these, we can get the average velocity across the pipe diameter :

$$V = \frac{MD}{\sin 2\theta} \cdot \frac{\Delta T}{T_{UP} \times T_{DOWN}}$$

The information contained herein is subject to change without notice.

7260 Series

Smart-IN^{US}

Ultrasonic Flow Meter

Technical Specifications

Liquids Measured

Water, sea water and other clean liquids with a content of suspended solids less than 20000ppm (mg / l) and without a high content of air bubbles.

-10°C ~ +70°C, without ice in pipes at low temperature

Pipe Materials Measured

Steel, stainless steel, cast iron, PVC, etc. (20 ~ 6000mm)

Up & Down Stream Straight Runs

In the upstream, it must be 10D and in the downstream 5D.

If there's a pump in the upstream, the length must be at least 30D from the pump.

Flow Velocity

0 ~ ±32m/s

Measurement Accuracy

±0.5 ~ 1% of rate

Repeatability : ±0.2 ~ 0.5 % at 0 ~ ±32 m/s

Linearity : ±0.5%

Pipe size : 20mm ~ 6000mm (ID)

Display

NR

Output

4 ~ 20mA(precision 0.1%)

RS-232C serial output.

RS-485

Power Requirement

DC 15~24V (Standard DC 24V ±10%)

Operating Condition

Host : Temp. : -10 ~ +70°C

Humid : 85% RH max.

Sensor : Temp. : -30~+150°C

Humid : 98% RH max.

(able to operate immersed in water depth of 3m max.)

Weight

Host : 110g

Host Size

Host : 118mm(L) x 72mm(W) x 43mm(H)

Sensor Distance

The distance takes the fronts edges as the standard.

After inputting the necessary parameter, check up the numbers displayed in M25 window, sensors and pipe wall.

At the some time, on the horizontal pipe sensors must be mounted horizontally and symmetrically, to prevent existing air bubble on the upper part in the pipe, this will effect the measurement precision.

Pay attention to the mounting direction. (MFG. Setting)

Series 7260 SYSTEM SCHEMATIC

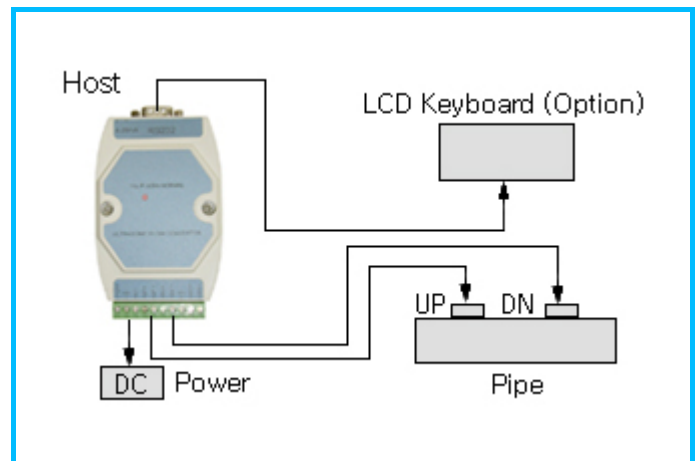

Transducer Type

- Standard - S (15 ~ 100 mm range)
- Standard - M (50 ~ 700 mm range)
- Standard - L (300 ~ 6000 mm range)

Application

- Water supply, draining off and the processor of filthy water
- Oil field, petroleum chemical engineer system
- Power plant (heat power, water power, fire power)
- Steel factory, mining industry
- Food, Medicine, paper-made
- Automobile making and check-up
Semi-conductor (Pure water)
- Heat net balance of heat supply system

Sensor Installation

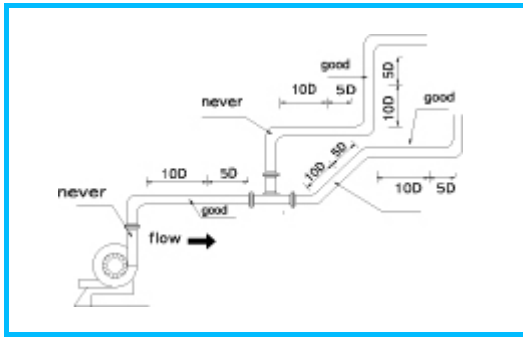

Site Selection

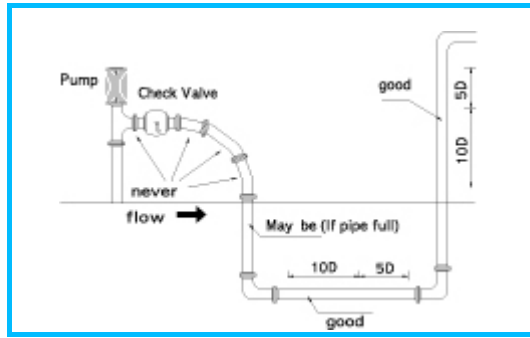

Sensor Location

Mounting method of sensor

There are two mounting methods, “V” method and “Z” method :

“V” method : usually “V” method is the standard method. It’s easier to install and offers high grade of accuracy. The scope of pipe diameter that “V” method can measure is 50 ~ 350mm; while mounting, two sensors should be horizontal and aligned, their axis and the center lines should be aligned.

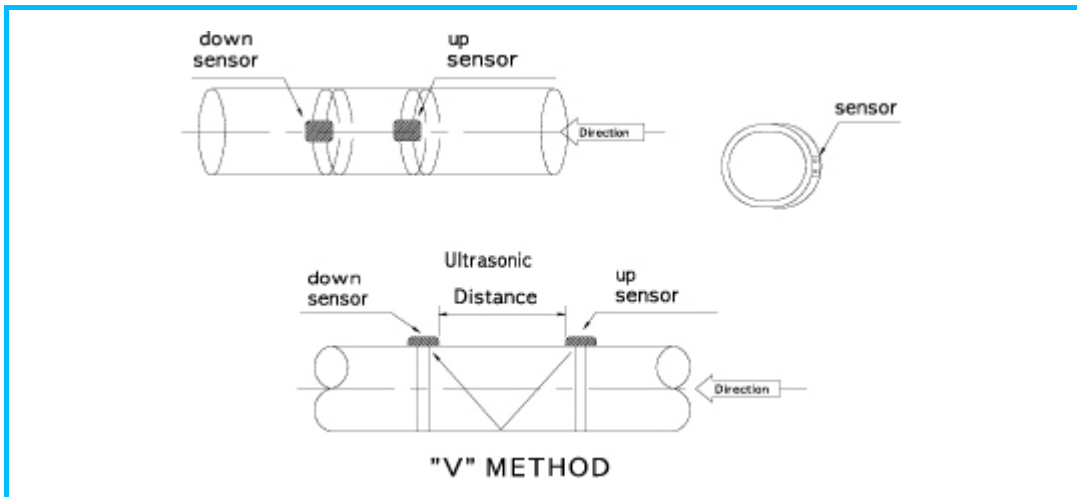

“Z” method : When the signal can be attenuated or interfered by scale quilted up inside pipe, by a thick liner, suspended solids in the fluid, etc., use “Z” method instead Using “Z” method ultrasonic wave spreads in the pipe directly without diffraction (straight sound signal path)

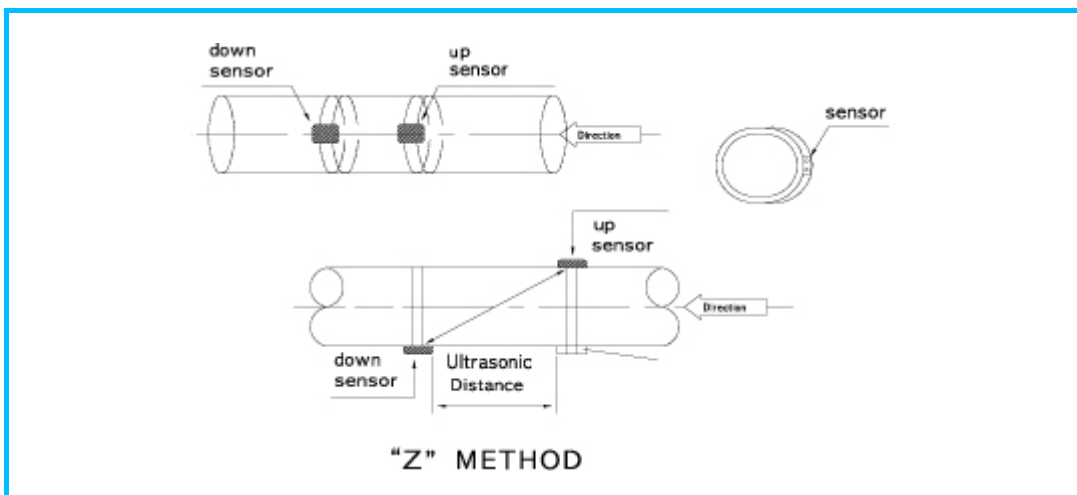

Various Ultrasonic Sensor

1. Clamp-on Sensor Type



Standard "S" (Magnetic)
DN15 - DN100
Fluid Temp. < 80°C



Standard "M" (Magnetic)
DN50 - DN700
Fluid Temp. < 80°C



Standard "L"
DN300 - DN6000
Fluid Temp. < 80°C

2. Insert Type

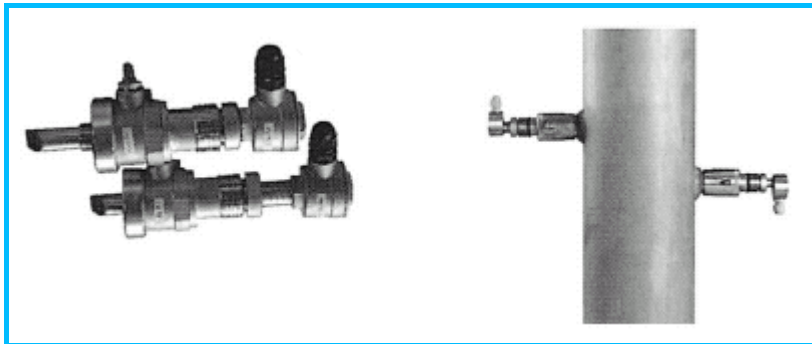

Wetted "WS"

- (1) Wetted Type (WS)
DN50 ~ Fluid Temp. < 120°C

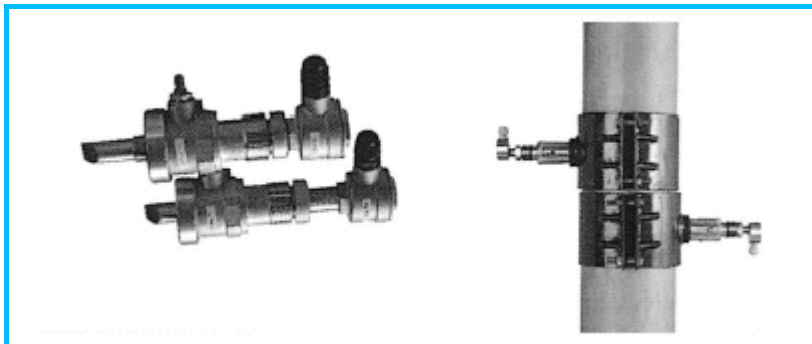

Cast iron Pipe Band "CI"

- (2) Cast iron Pipe Type (CI)
DN50 ~ Fluid Temp. < 120°C

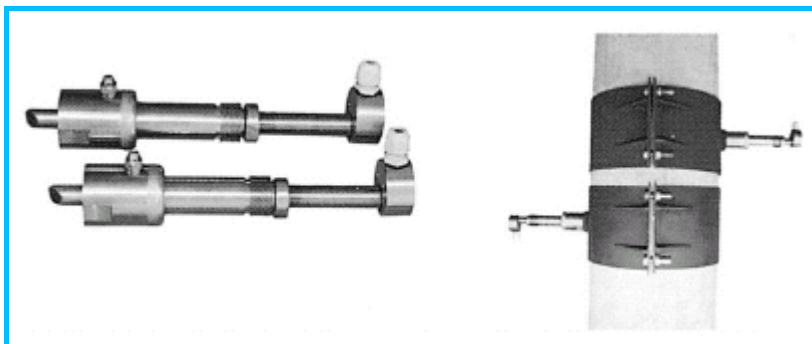

Cement Pipe Band "CB"

- (3) Cement Pipe Bend (CB)
DN100~ Fluid Temp. < 120°C

3. Standard “л” pipe Sensor Type

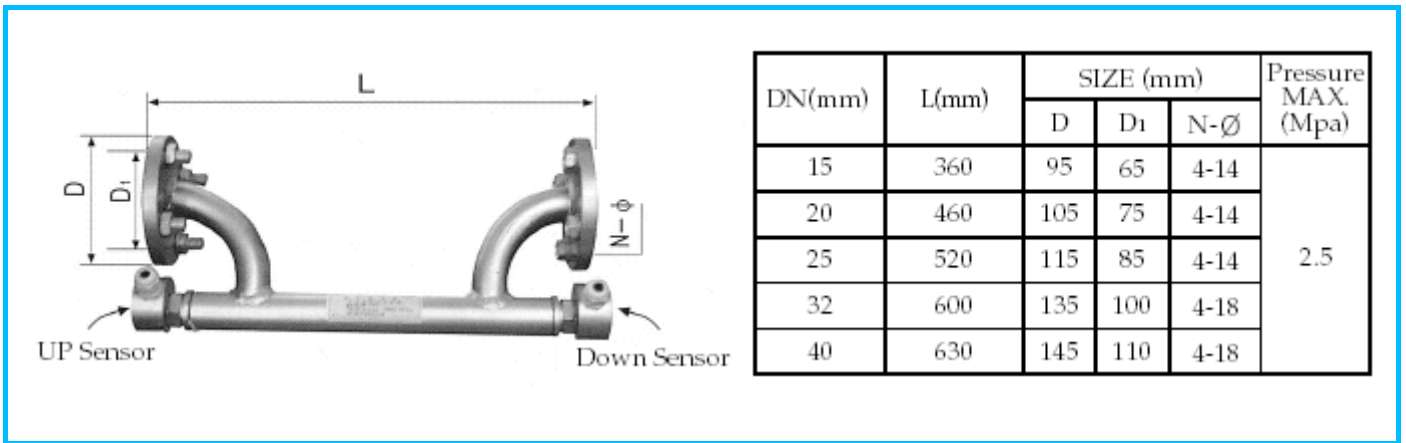

4. Flange Type

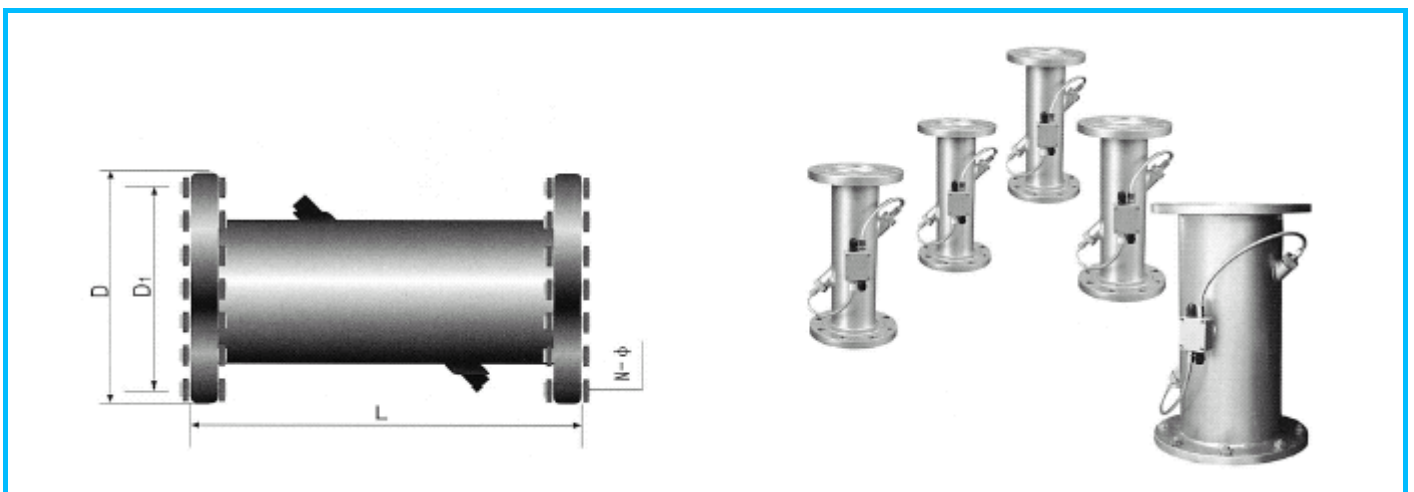

PIPE DIA DN(mm)	PIPE LENGTH (mm)	SIZE (mm)			Max. Pressure (Mpa)
		D	D1	N-Ø	
50	350	160	125	4-18	1.6
65	350	180	145	4-18	
80	350	195	160	8-18	
100	400	215	180	8-18	
125	425	245	210	8-18	
150	450	280	240	8-23	
200	500	335	295	12-23	
250	575	405	355	12-25	
300	650	460	410	12-25	
350	700	520	470	16-25	
400	750	580	525	16-30	
450	800	640	585	20-30	
500	850	705	650	20-34	
600	950	840	770	20-41	

Dimensional Specification

- Series 7260 HOST (Front View)



- Series 7260 HOST (Side View)

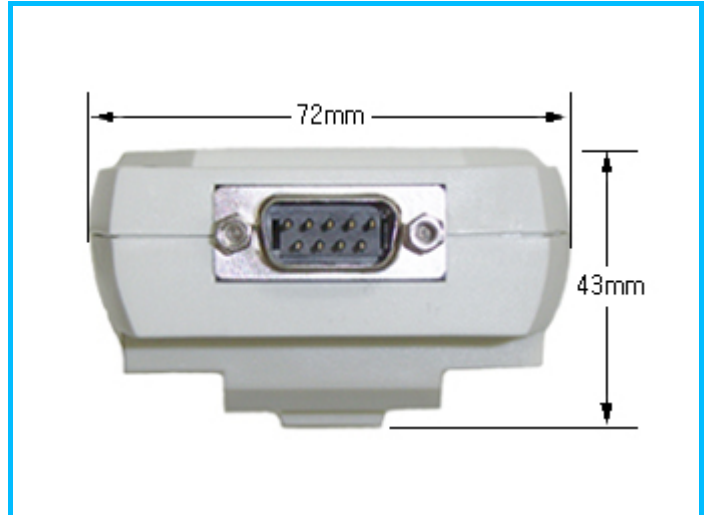

Host Size : 118mm(L) x 72mm(W) x 43mm(H)

Wiring Connection (UFT-7260)



- Series 7260 Wiring Connection

UFT-72

Type	6	0	S
1			

 -

Agency			
2			

 -

Sensor Type		
3		

 -

Power	P	
4		

 -

Output	V	
5		

 -

Display	N	R
6		

 -

Cable Con.		
7		

 -

Cable Len.		
8		

 -

Enclosures		
9		

 -

Pipe D.	D	
10		

 -

Option		
11		

Model Direction	Code 1
MINI Ultrasonic Flow Meter	60
Agency approved, customer specified	WW

Agency Approvals	Code 2
Non-Agency Approved Meter	NAA
Agency approved, customer specified	WW

Sensor Type		Code 3
Clamp-on transducer	"S"	CS
Clamp-on transducer	"M"	CM
Clamp-on transducer	"L"	CL
Wetted transducer	"WS"	WS
Cast Iron Pipe Bend	"CI"	CI
Cement Pipe Bend	"CB"	CB
Standard "π" pipe	DN15	D15
Standard "π" pipe	DN20	D20
Standard "π" pipe	DN25	D25
Standard "π" pipe	DN32	D32
Standard "π" pipe	DN40	D40
Flange type	DN ()	F ()
* DN() : 50-600 mm		
Agency approved, customer specified		WW

Input Power	Code 4
DC24V ±10%	P2
Agency approved, customer specified	WW

Output	Code 5
4 ~ 20mA	V1
RS-232C	V2
RS-485	V3
Agency approved, customer specified	WW

Display	Code 6
No Readout	NR
Digital Display	DD
Agency approved, customer specified	WW

Cable Connector	Code 7
Standard Connector	SC
BNC Connector	BC
Agency approved, customer specified	WW

Cable Length	Code 8
Standard Length (5m)	S5
Special Length ()m	S()
Agency approved, customer specified	WW

Enclosures	Code 9
NEMA 1(IP23)	EN2
Agency approved, customer specified	WW

Pipe Dimension	Code 10
Pipe Dia. DN () mm	D()
Not Application	NA
Agency approved, customer specified	WW

Option	Code 11
Pressure Test Certificate	PT
Certificate of Conformance	CC
NACE Certificate	NC
Agency approved, customer specified	WW

CUSTOMER INFORMATION

CUSTOMER INFORMATION																					
Customer Name & Address :	P.O. No :																				
	Customer Order No:																				
Contact :	Tag Number(s) :																				
Phone :																					
Fax :	E-mail :																				
PROCESS DETAILS	INSTRUMENT DETAILS																				
Application Description Describe type of application (example; boiler feed, flare gas, etc.)	Flow Element Mounting <input type="checkbox"/> Horizontal pipe, side mount, flow left to right <input type="checkbox"/> Horizontal pipe, side mount, flow right to left <input type="checkbox"/> Horizontal pipe, top mount, flow left to right <input type="checkbox"/> Horizontal pipe, top mount, flow right to left <input type="checkbox"/> Vertical pipe, Flow up <input type="checkbox"/> Vertical pipe, Flow down																				
Process Media Include gas name and percent composition by volume (moles) or Weight (mass). Please attach a gas composition list or fill in composition below. Total composition must add up to 100% Gas Components : <input type="checkbox"/> % Volume (moles) <input type="checkbox"/> % Weight (mass) _____ % _____ % _____ % _____ % _____ % _____ %	Flow Transmitter Setup Input Power : <input type="checkbox"/> 110VAC ± 10% <input type="checkbox"/> 220VAC ± 10% <input type="checkbox"/> 24VDC ± 10% <input type="checkbox"/> 90 ~ 240 VAC Application : <input type="checkbox"/> Flow (default) <input type="checkbox"/> Totalize Signal Output : <input type="checkbox"/> 4 to 20mA <input type="checkbox"/> 1 to 5VDC <input type="checkbox"/> 0 to 5VDC <input type="checkbox"/> 0 to 10VDC <input type="checkbox"/> RS-232C Flowrate Units _____ Zero Value _____ Full Scale _____ Alarm Set points _____																				
Process Conditions <table style="width: 100%; border-collapse: collapse;"> <thead> <tr> <th style="width: 10%;"></th> <th style="width: 15%;">Nominal</th> <th style="width: 15%;">Minimum</th> <th style="width: 15%;">Maximum</th> <th style="width: 15%;">Flow Units</th> </tr> </thead> <tbody> <tr> <td>Flow Rate :</td> <td>_____</td> <td>_____</td> <td>_____</td> <td>_____</td> </tr> <tr> <td>Temperature :</td> <td>_____</td> <td>_____</td> <td>_____</td> <td>_____</td> </tr> <tr> <td>Pressure :</td> <td>_____</td> <td>_____</td> <td>_____</td> <td>_____</td> </tr> </tbody> </table>		Nominal	Minimum	Maximum	Flow Units	Flow Rate :	_____	_____	_____	_____	Temperature :	_____	_____	_____	_____	Pressure :	_____	_____	_____	_____	Standard Temperature and Pressure 70 °F and 14.7 psia [21.1 °C and 1.013 bar(a)] is the factory calibration default for standard temperature and pressure unless otherwise indicated below. Standard <input type="checkbox"/> 70 °F [21.1 °C] <input type="checkbox"/> 14.7 psia [1.013 bar(a)] Other _____
	Nominal	Minimum	Maximum	Flow Units																	
Flow Rate :	_____	_____	_____	_____																	
Temperature :	_____	_____	_____	_____																	
Pressure :	_____	_____	_____	_____																	
Required Dimensions Pipe/Duct Size (ID and units of measurement) _____ B-dimension per diagram below : _____ Upstream straight length pipe/duct : _____ Downstream straight length pipe/duct : _____ Upstream disturbance _____	Note (Remark) 																				
Installation Details or Drawing Hot tap <input type="checkbox"/> No <input type="checkbox"/> Yes																					